

SMHC50

Configuration parameter

Parameter		Parameter
Engine	Type	Isuzu GH-6HK1XKSC-01
	Rated power	212 kW/2000 rpm
	Max. torque	1080Nm/1500rpm
	Exhaust standard	III stage
	Cylinder/Displacement	6/7.79L
Fuel tank capacity		540L
Movable boom		8.6m
Loading stick		6m
Working radius		13.5m
Working height		13.5m
Working depth		-4.5m
Cabin lifting height		2.65m
Max. rotation speed		8 r/min
Rotation radius		3.55m
Crawler base	Track distance	Extend: 3.8m Retract: 2.52m
	Wheel spacing	4.1m
	Max. Travelling speed	5km/h
Hydraulic	Type	Kawasaki K5V160DTH1x7R-0E40-BV
	Displacement	387 ml/r
Main valve		Kawasaki KMX15RB/B4606-EV1
Slewing bearing		STE SSF1405/50CWH II
Gear reducer		Kawasaki M5x180CHB-10A-6RA/265-RG20D25
Movable boom cylinder		Kawasaki KHCV25P-A220-3.1/395
Loading stick cylinder		Kawasaki KHCV25P-A219-3.1/395
System pressure value		32MPa
Hydraulic tank		380L

SMHC50

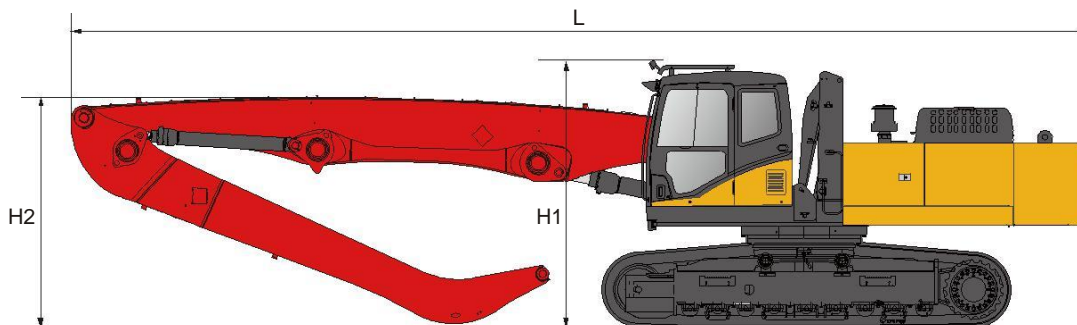

	The length of movable boom hinge point	The length of stick boom hinge point	L	H1	H2
Boom combination	8.6m	6m	12.585m	3.303m	2.918m



SANY MARINE HEAVY INDUSTRY CO., LTD.

SANY Industrial Park, Gaolan Port Economic and Development Zone, Zhuhai, Guangdong, China

Tel 0756-7266927 Service 4008 87 8318
 Fax 0731-84031999-149 Consulting 4008 87 9318
 Email sanyport@sany.com.cn



B03S2CHAS0808-CP

Materials and specifications are subject to change without notice. Featured machines in photos may include additional equipment. Copyright and all rights reserved.