

# SAC6000

SANY All Terrain Crane  
600 Tons Lifting Capacity



Max. Lifting Capacity: 600 t  
Max. Boom Length: 90 m  
Max. Lifting Height: 136 m

## Excellent and stable chassis performance

The use of innovative 8-axle chassis design with six driving modes and four braking modes, providing more reliable traveling performance. High stability and safety are guaranteed with tipping over early-warning technology.

## Ultra long Boom for Wide Working Radius

- ▣ The Max. length of boom and tower jib is 90m respectively, which ensures Max. lifting height with tower jib up to 136m. Fixed jib is 42m and are equipped with 0°~40° infinitely automatically variable luffing , ensuring conveniently switching over between all operating conditions with high efficiency.



## Highly efficient, energy-saving and unique hydraulic control technology

- Self-developed dual-pump converging / diversion main valve is used. Converging flow of the single-action dual-pump ensures fast operation and high work efficiency, combined-action dual-pump diversion system is applied to ensure stable controllability. Electric proportional variable displacement piston pump is used to ensure high-accurate flow control with higher efficiency and energy saving.

## Safe, stable, advanced, and intelligent electronic control technology

- The adoption of internationally advanced distributed integration bus data communication network and the configuration of abundant sensing elements can achieve timely feedback of data information and monitor the overall working status in real-time. The human-computer interaction interface is used to meet with customer's individual requirements.



# Overall Dimensions

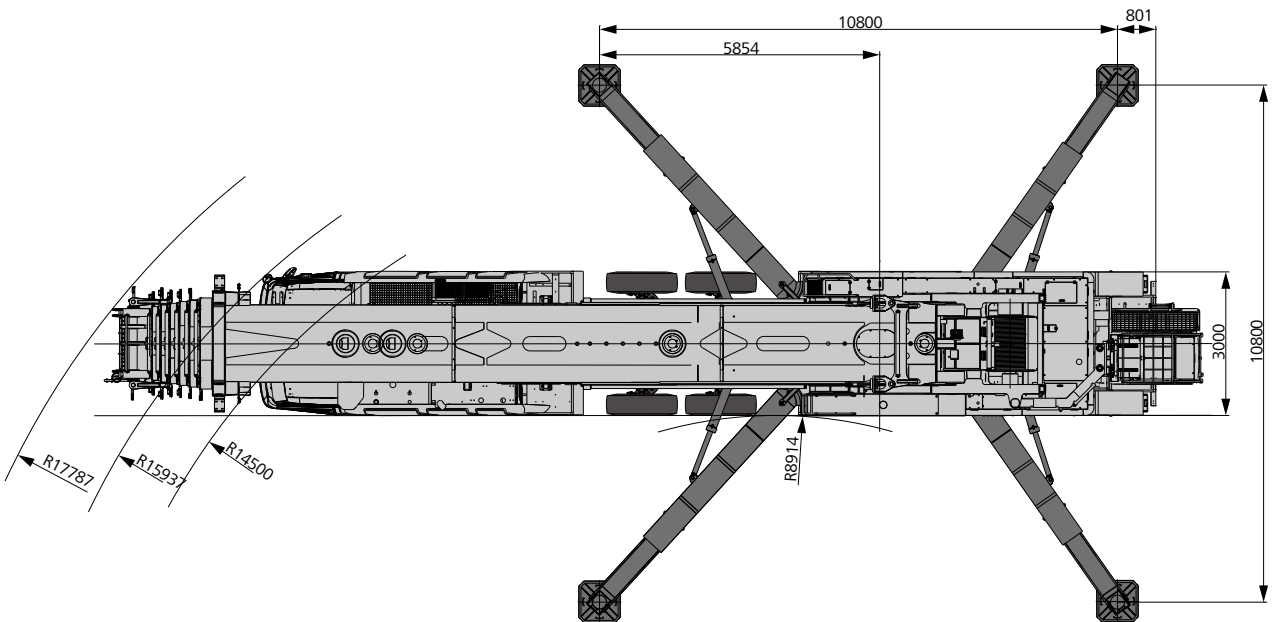
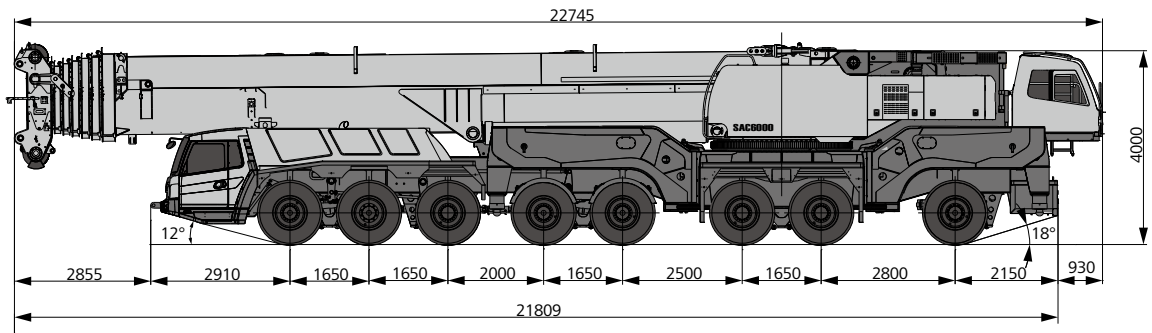

## Technical Parameters

| Type                                      | Item   | Parameter                       |             |
|---|--|---------------------------------|-------------|
| Capacity                                  | Max. lifting capacity                                      | 600 t                           |             |
| Dimensions                                | Overall length   | 22745mm                         |             |
|   | Overall width  | 3000mm                          |             |
|   | Overall height   | 4000mm                          |             |
|   | Axle distance  | Axle-1,2                        | 1650mm      |
|   |  | Axle-2,3                        | 1650mm      |
|   |  | Axle-3,4                        | 2000mm      |
|   |  | Axle-4,5                        | 1650mm      |
| Axle-5,6                                  |  | 2500mm                          |             |
| Axle-6,7                                  |  | 1650mm                          |             |
| Weight                                    | Weight of travelling mode*                                 | 96000kg                         |             |
|   | Axle load  | Axle load-1,2,3,4               | 12000kg     |
|   |  | Axle load-5,6,7,8               | 12000kg     |
| Engine                                    | Rated power (under carriage)                               | 480kW / 1800rpm                 |             |
|   | Rated torque (under carriage)                              | 3000N.m / 1300rpm               |             |
|   | Rated power (super structure)                              | 205kW / 2200rpm                 |             |
|   | Rated torque (super structure)                             | 1100N.m / 1400rpm               |             |
| Traveling                                 | Max.traveling speed  | 75km/h                          |             |
|   | Turning radius   | Min.turning radius              | 14.5m       |
|   |  | Min.turning radius of boom head | 17.8m       |
|   | Wheel formula  | 16 × 8                          |             |
|   | Min.ground clearance                                       | 310mm                           |             |
|   | Approach angle   | 12 °                            |             |
|   | Departure angle  | 18 °                            |             |
|   | Max.gradeability   | 37.4%                           |             |
|   | Fuel consumption per 100km                                 | ≤ 125L                          |             |
| Main Performance Data                     | Temperature range  | - 20 ° ~ + 50 °                 |             |
|   | Min.rated range  | 3 m                             |             |
|   | Tail slewing radius of swingtable                          | 6950 mm                         |             |
|   | Boom section   | 7                               |             |
|   | Boom shape   | U-shaped                        |             |
|   | Max.lifting moment   | Base boom                       | 18228 kN·m  |
|   |  | Full-extend boom                | 11900 kN·m  |
|   |  | Full-extend boom+jib            | 4025 kN·m   |
|   |  | Full-extend boom+lattice jib    | 6420 kN·m   |
|   | Boom length  | Base boom                       | 17.1 m      |
|   |  | Full-extend boom                | 90 m        |
|   |  | Full-extend boom+jib            | 128 m       |
|   |  | Full-extend boom+lattice jib    | (50.6+90) m |
| Outrigger span (Longitudinal×Transversal) | 10.8 × 10.8 m  |                                 |             |
| Jib offset                                | 0 °—40°  |                                 |             |
| Working speed                             | Max.single rope lifting speed of main winch (no load)      | 130 m/min                       |             |
|   | Max.single rope lifting speed of auxiliary winch (no load) | 130 m/min                       |             |
|   | Full extension/retraction time of boom                     | 1200 / 1200 s                   |             |
|   | Full lifting/descending time of boom                       | 75 / 80 s                       |             |
|   | Slewing speed  | 0.9 r/min                       |             |
| Air condition                             | Superstructure   | Cooling / Heating               |             |
|   | Chassis  | Cooling / Heating               |             |

Notes: weight of travelling mode means that the weight without boom of 3,4,5,6,7 section and two rear outriggers.

## Technical Parameters



### Axle load

| Axle          | 1  | 2  | 3  | 4  | 5  | 6  | 7  | 8  | Overall mass |
|---------------|----|----|----|----|----|----|----|----|--------------|
| Axle load / t | 12 | 12 | 12 | 12 | 12 | 12 | 12 | 12 | 96           |
| Remarks       | -  |    |    |    |    |    |    |    |              |



### Hook and multiplying power

| Rated load/t | Pulleys | Number of parts of line | Hook weight/kg |
|--------------|---------|-------------------------|----------------|
| 250          | 11      | 23                      | 4200           |
| 160          | 7       | 15                      | 3900           |
| 80           | 3       | 7                       | 2700           |
| 13.5         | 0       | 1                       | 700            |

## Crane Introduction

| No | Name                     | Manufacture |
|----|--------------------------|-------------|
| 1  | Chassis Engine           | Benz        |
| 2  | Superstructure engine    | Benz        |
| 3  | Axle 1                   | KESSLER     |
| 4  | Axle 2                   | KESSLER     |
| 5  | Axle 3                   | KESSLER     |
| 6  | Axle 4                   | KESSLER     |
| 7  | Axle 5                   | KESSLER     |
| 8  | Axle 6                   | KESSLER     |
| 9  | Axle 7                   | KESSLER     |
| 10 | Axle 8                   | KESSLER     |
| 11 | Transmission             | ZF          |
| 12 | Transfer case            | KESSLER     |
| 13 | Main lifting piston pump | Rexroth     |
| 14 | Luffing piston pump      | Rexroth     |
| 15 | Telescoping piston pump  | Rexroth     |
| 16 | Telesoping balance valve | WESSEL      |

# Technical Parameters

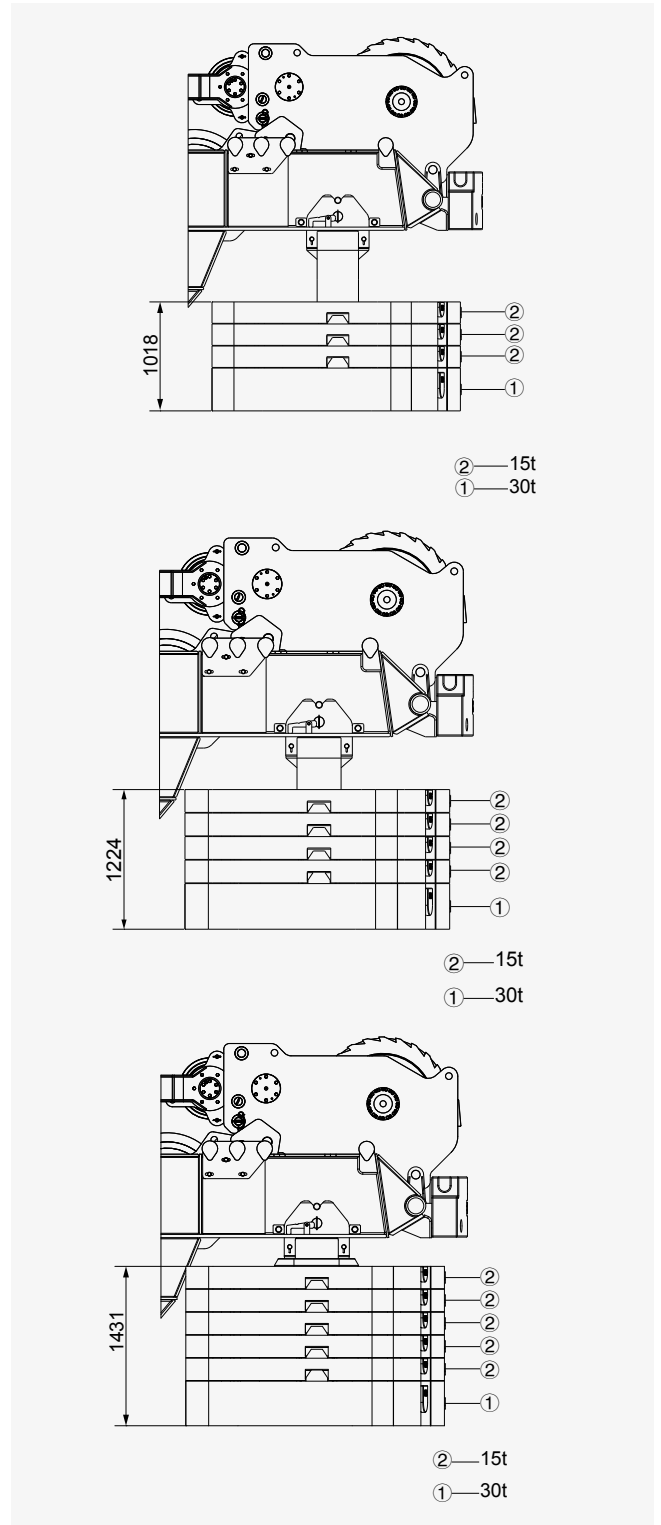
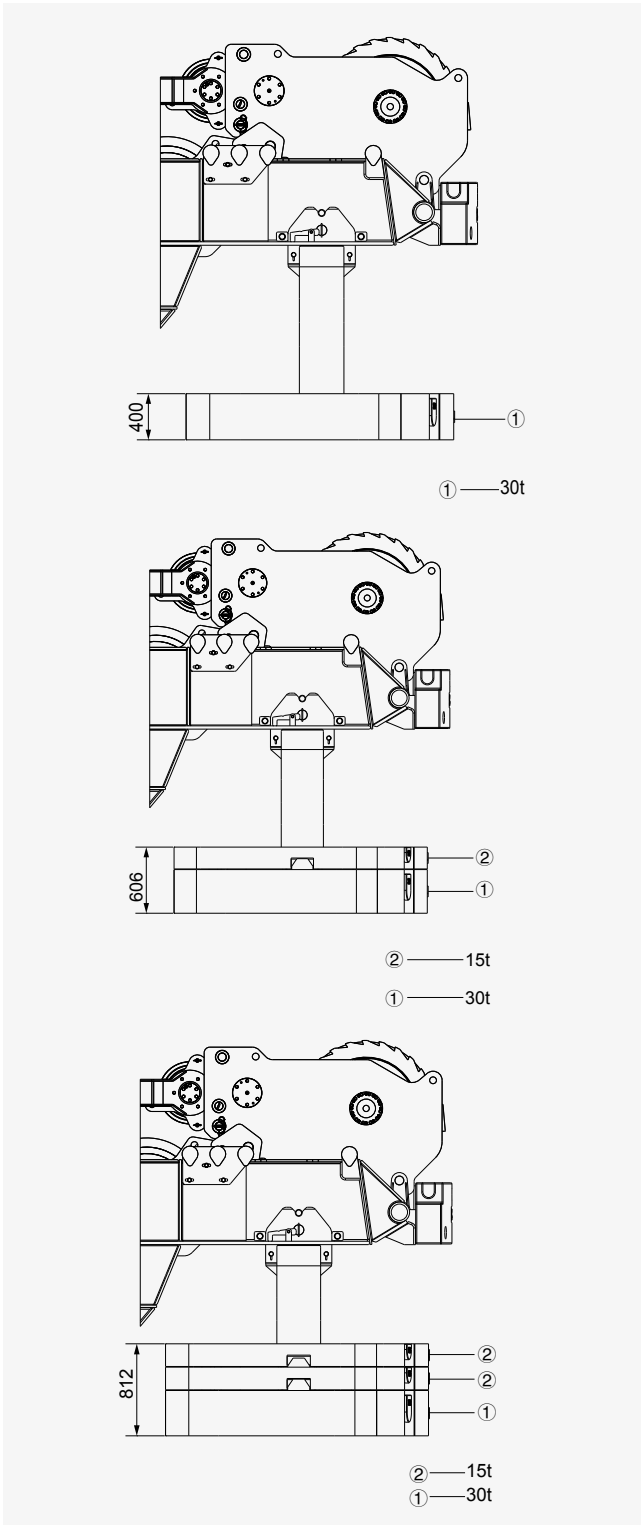

# Technical Parameters

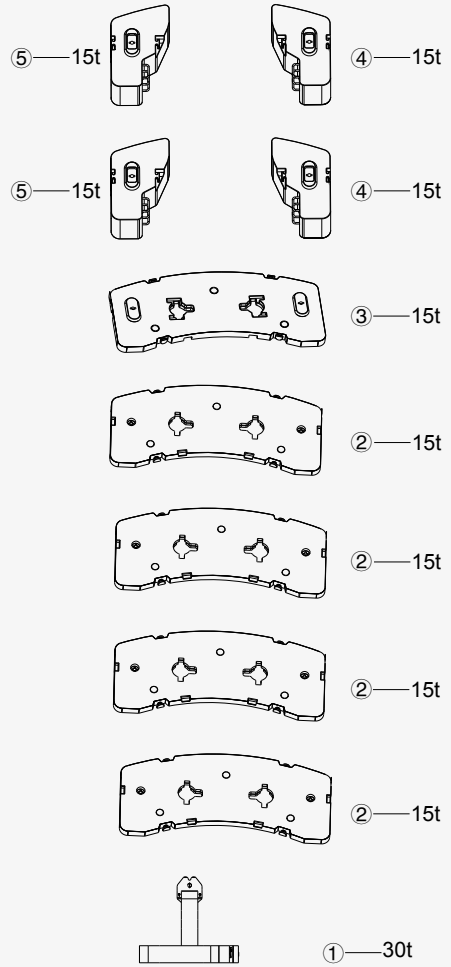
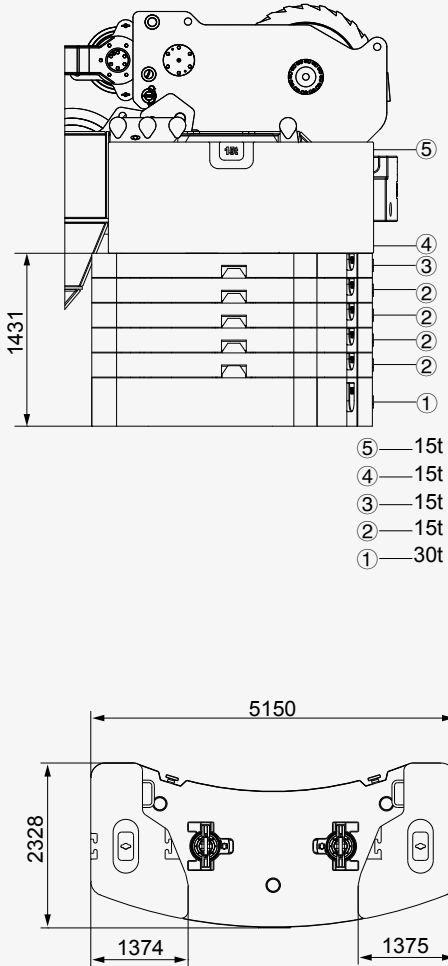

## Crane Introduction

### Cab

- It is made of safety glass and anti-corrosion steel plate with ergonomic design such as full-coverage soften interior, panoramic sunroof and adjustable seats etc. humanized design, providing more comfortable and relaxing operation experience. The display of load moment limiter integrates main console and operation display system, which clearly show the data of all operating superstructure conditions for lifting operation.

### Engine

- Type: Inline six-cylinder, water cooled, supercharged and inter-cooling diesel engine
- Rated power: 205kw/2200r/min
- Environment-protection: Emission complies with EuroII standard
- Capacity of fuel tank: 400L

### Hydraulic system

- The adoption of high-quality hydraulic components ensures high reliability and long service life. Accurate parameter matching provides more excellent operation performance.
- The electric proportional variable displacement piston pump is used to adjust the pump displacement in real-time through changing the opening of the electrical control handle, thus achieving high-precision flow control with no-loss of energy during operation.
- Self-developed dual-pump converging / diversion main valve is used with multiple pressure selection function to satisfy the pressure demands of different working conditions, ensuring stable overall crane action and reducing energy consumption.
- Main winch adopts the closed winch system with high working efficiency and low energy cost, ensuring excellent micro-mobility and stability of winch. It is equipped with four level protection system, making winch system more secure and reliable.
- The use of dead-weight luffing compensation hydraulic system ensures excellent lowering micro-mobility and stability.
- The unique single-cylinder pin locking telescopic boom technology is adopted, providing higher reliability with cylinder boom pin interlock combining mechanic, electric and hydraulic triple protections, ensuring high reliability.
- The closed system is used by slewing system to avoid the energy-saving cost of the open system, ensuring higher efficiency. The system has load sensitive features, low speed travelling under heavy load and high speed travelling under light load and high action efficiency functions. Emergency brake and slow brake can be achieved through electric proportion pressure reduce valve, which makes movement more stable and efficient.

### Luffing system

- The top double-cylinder luffing is applied with luffing angle ranging from  $-0.5^{\circ}$ ~ $86^{\circ}$ . Hydraulic system adopts the dual-pump converging open hydraulic circuit and combine electro proportional control, power lowering with self-weight luffing, achieving large-angle fast lowering and small-angle stable and slow lowering operations.

### Telescopic boom

- It consists of seven section booms welded with bended fine-grain high-strength steel plate, with oval section applied to ensure good buckling resistance performance, with single-cylinder automatic pin system, a dual-action cylinder can control telescopic operation of all booms and achieve a variety of boom combinations.
- Standard configuration of boom end pulley is 13 pulleys.
- The boom length is 90m.

### Lattice jibs

- There are fixed jib and tower jib. The adaptor, jib head, and 6m and 12m large (small) sectional standard sections are shared by fixed jib and tower jib. 12m~42m boom combination can be achieved for fixed jib. The application of  $0^{\circ}$ ~ $40^{\circ}$  infinitely luffing jib improves automation level and working efficiency through changing the angle according to the actual demands of the operating condition. With tower jib equipped with 24m~90m jib combination, thus greatly improving lifting capacity and operating height.
- Equipped with 6m special jib for wind turbine installation, featuring good adaptability to wind turbine working conditions and strong lifting capacity.

### Superlift devices

- The stress applied on the lifting boom can be reduced to avoid side bending and to reduce down-warping deformation. Therefore, under long boom state, deflection can be reduced and the lifting capacity can be improved.

### Slewing system

- It consists of constant displacement motor and slewing reducer with mature technology.  $360^{\circ}$  rotation can be achieved through external gearing with slewing ring. With slewing speed of 0-0.9rpm and with infinitely variable speed adjustment. Slewing hydraulic system adopts the closed system, which not only avoids throttling loss of the open system but also ensures a high efficiency. Emergency brake can be achieved through electric proportional brake pedal.

## Crane Introduction



### Control system

- The PLC integrated programmable controller and CAN-bus control network are used to achieve logic control and electric proportional control of the system by combining with the common electricity.
- With real-time monitoring and fault self-diagnosis system except for normal control function.
- Lifting, slewing and luffing can be controlled by electrical proportion of lifting, Lifting and lowering of counterweight, shifting of cab and locking of rotating bed can be controlled through the keys on the control panel.
- Display can be connected with the controller via CAN-bus with main functions as follows: digital adjustment and display of the electric proportional control parameters, display of fault code of the electric proportional system and real-time data display by the hydraulic system.



### Main hoisting system

- Planet-gear speed reducer and special groove winch drum are driven by hydraulic motor with brake installed internally.
- Wire rope lock: High-quality wire rope lock with casting at ends is applied. It is installed in the lock sleeve directly, which improves the replacement speed of the lifting rate.
- Spec. of wire rope:  $\phi$  25, non-rotating.
- Length: About 760m.
- Max. single rope speed (outer layer): about 130m/min.



### Tower boom winch mechanism

- Planet-gear speed reducer and special groove winch drum are driven by hydraulic motor with brake installed internally. Anti-winding wire rope is used. Separate rotation can be achieved together with the auxiliary hoisting system.
- Spec. of wire rope:  $\phi$  25, non-rotating.
- Length: About 1100m.
- Max. single rope speed (outer layer): about 130m/min.



### Safety system

- Load moment limiter: With analytical mechanics method, the load moment limiter calculation system is established based on the load mechanical model. The rated hoisting accurate can be up to  $\pm 3\%$  through on-line non-load calibration.
- Hydraulic system is configured with the balance valve, overflow valve, and two-way hydraulic lock etc., ensuring stable and reliable operation of the hydraulic system;
- Main and auxiliary winches are configured with 3-wraps protectors to prevent over roll-out of wire rope.
- Boom and jib are configured with height limiters at ends to prevent over-hoist of the wire rope.
- Boom head is equipped with anemometer to detect whether the high-altitude wind speed is within the allowable range.
- With superlift rope rewinding and release pull protection procedure and tower (jib) boom installation and lifting load protection procedure.



### Counterweight

- Combined variable counterweights are used with 0t, 30t, 45t, 60t, 75t, 90t, 105t, 135t, 165t nine combinations to meet requirements of different operating conditions and maximize structural parts performance, which can be self-assembled and disassembled.

## Crane Introduction

### Operating cab

- Cab is made of new steel structure self-developed by SANY, featuring excellent shock absorption and tightness, It is configured with swing-out doors at both sides, pneumatically suspended driver's seat and passenger's seat, adjustable steering wheel, large rearview mirror, comfortable driver's chair with a headrest, anti-fog fan, air conditioner, stereo radio and complete control instruments and meters, providing more comfortable and safe operation experience.

### Carrier frame

- Designed and manufactured by SANY, anti-torsion box structure is welded by fine-grain high-strength steel plate to provide strong load bearing capacity.

### Axles

- Full-axle steering is applied with axles 1, 2, 4 and 5 used for drive operation, axles 1, 2, 3 and 4 adopt the bar-feedback hydraulic power steering systems and axles 5,6,7 and 8 adopt the electrohydraulic control steering system with assist in speed control and special steering mode optional applied, thus ensuring easy steering and flexible operation.

### Engine

- Type: Electric controlled, V- type eight-cylinder, water cooled, supercharged and inter-cooling diesel engine.
- Rated power: 480kw/1800r/min.
- Max torque:3000Nm/1300rpm.
- Environment-protection: Emission complies with EuroIV standard.
- Capacity of fuel tank: 550L.

### Transmission system

- Gearbox: Manual /Automatic gearbox is adopted with 12-gear and large speed ratio range applied, which meets the requirements of low gradeability speed and high speed traveling.
- Transfer case: Transfer case with a large input torque is used with rated torque up to 30000N.m and with differential lock cylinder configured.
- Transmission shaft: With optimized arrangement of the transmission shaft, the transmission is more stable and reliable. For most optimized transmission, face-tooth coupling transmission shaft is used with large transmission torque.

### Tyres

- 12\*—16.00R25.

### Brakes system

- To ensure its reliability and security of brake system, it consists of 4 independent types of brake systems.
- Traveling brake: All wheels use dual-circuit pressure brakes
- Parking brake: Spring accumulator is used for cutting-off brake;
- Emergency brake: Spring accumulator is used not only for cutting-off brake but also for emergency brake;
- Slow brake: Engine is equipped with dual brake and transmission equipped with hydrodynamic retarder brake, five-bridge eddy-current retarder brake.

### Suspension system

- Axle suspension devices adopt the height-adjustable oil-gas suspension devices equipping with the hydraulic lock with stroke of suspension cylinder of +160/-130mm to achieve suspension, rigid locking, automatic leveling, overall lifting and lowering, single-point lifting and lowering modes. Load applied on each axle is no more than 12t. With good trafficability and adaptability of a variety of severe operating conditions and road, smooth and comfortable travelling and side stability of the vehicle are guaranteed.

### Steering system

- Servo power steering gear and dual-circuit system hydraulic steering device are used with emergency steering pump equipped.
- Six types steering modes: 1) Road running mode (default mode). 2) Full-wheel steering mode. 3) Crab-type mode. 4) Steering mode without deflection. 5) Independent rear-axle steering mode. 6) Steering mode with rear axle locked.

### Outriggers

- Four-point supporting of the X-shaped outriggers ensures easy operation and strong stability with Max. span up to 10.8m×10.8m. Outrigger telescopic hydraulic system adopts the electro proportional control technology with wireless remote control configured. Outrigger control panel can display all loads with automatic level function to ensure high control precision and simple operation.

### Electrical system

- With 24V DC power supply, cutting off power of the undercarriage can be achieved. Automotive lighting system is equipped. Vehicle actions such as throttle and outrigger control can be electrically controlled. Electrical system has strong detection, logic, and calculation capacity with fault self-diagnosis, centralized display and self-protection function.
- Chassis adopts CAN-bus system; multifunctional centralized display system is used. Power consumption is small with maximum value of only 5w. Four functional keys are provided on the user interface.LCD display is used, with adjustable contrast ratio.

# Boom Operating Range

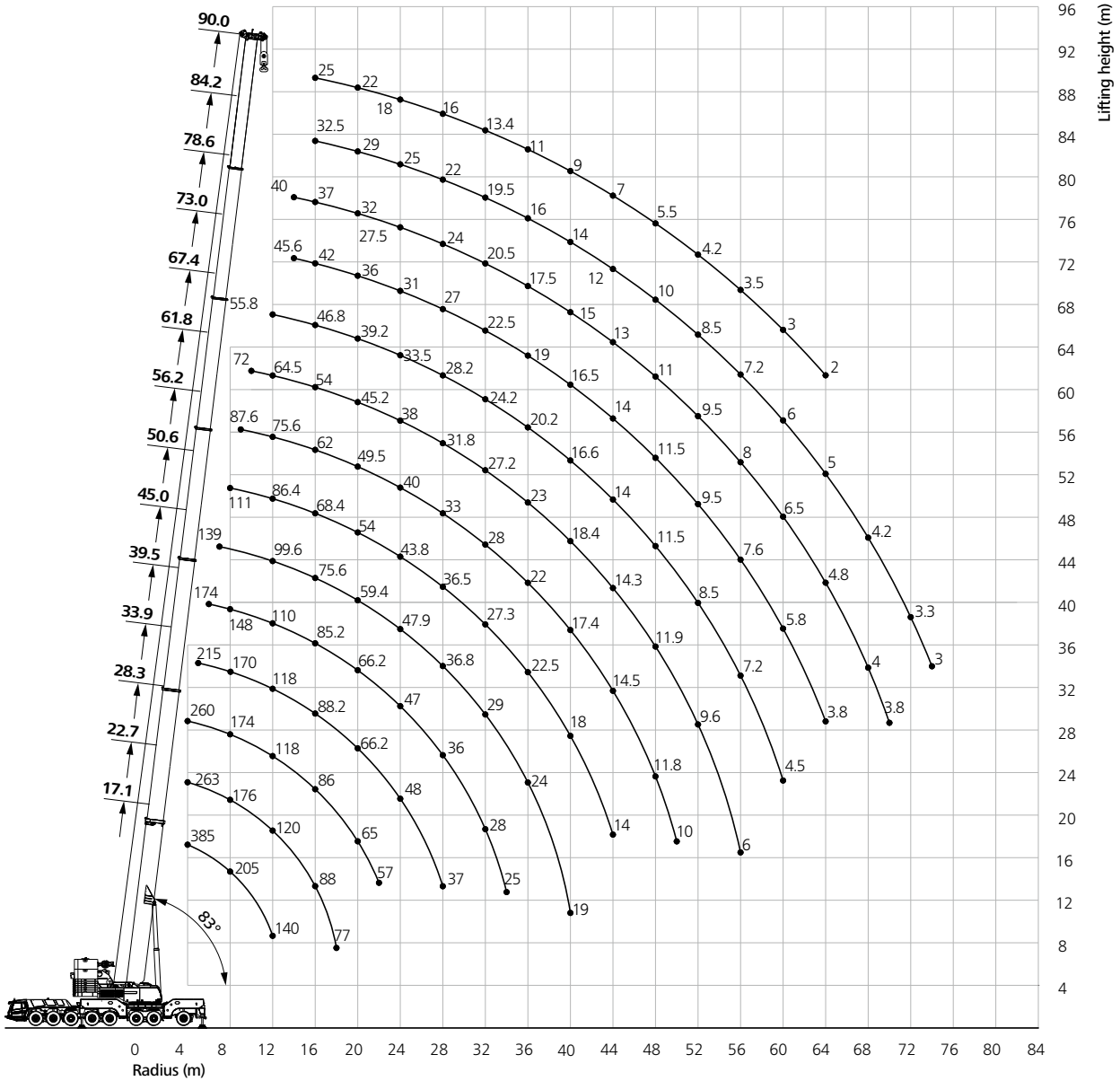

# Load Chart - Telescopic Boom

Unit: t

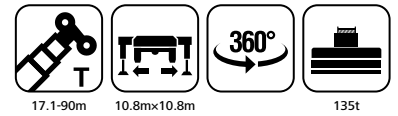

| Radius (m) | 17.1* | 22.7 | 28.3   | 33.9  | 39.5  | 45    | 50.6 | 56.2 | 61.8 | 67.4 | 73   | 78.6 | 84.2 | 90   | Radius (m) |    |
|------------|-------|------|--------|-------|-------|-------|------|------|------|------|------|------|------|------|------------|----|
| 3          | 600   |      |        |       |       |       |      |      |      |      |      |      |      |      | 3          |    |
| 3.5        | 440   | 263  |        |       |       |       |      |      |      |      |      |      |      |      | 3.5        |    |
| 4          | 385   | 263  | 260.4  |       |       |       |      |      |      |      |      |      |      |      | 4          |    |
| 4.5        | 292   | 262  | 250.95 |       |       |       |      |      |      |      |      |      |      |      | 4.5        |    |
| 5          | 288   | 246  | 235    | 219.6 |       |       |      |      |      |      |      |      |      |      | 5          |    |
| 6          | 250   | 220  | 212    | 201.6 | 174   |       |      |      |      |      |      |      |      |      | 6          |    |
| 7          | 225   | 196  | 194    | 187.2 | 159.6 | 139.2 |      |      |      |      |      |      |      |      | 7          |    |
| 8          | 205   | 176  | 174    | 169.8 | 147.6 | 128.4 | 112  |      |      |      |      |      |      |      | 8          |    |
| 9          | 190   | 159  | 157    | 154   | 136.8 | 120   | 105  | 87.6 |      |      |      |      |      |      | 9          |    |
| 10         | 186   | 144  | 142    | 140.4 | 127.2 | 112.8 | 98   | 82.8 | 72   |      |      |      |      |      | 10         |    |
| 12         | 140   | 120  | 118    | 118.5 | 110.4 | 99.6  | 87   | 75.6 | 64.5 | 55.8 | 49   |      |      |      | 12         |    |
| 14         | 105   | 103  | 101    | 101.7 | 96    | 87.6  | 76   | 68.4 | 59   | 51.6 | 45.6 | 40   |      |      | 14         |    |
| 16         |       | 88   | 86     | 88.2  | 85.2  | 75.6  | 68.4 | 62   | 54   | 46.8 | 42   | 37   | 32.5 | 25   | 16         |    |
| 18         |       | 77   | 75     | 77.2  | 77.2  | 66    | 60   | 55   | 49.5 | 43   | 39   | 34.5 | 30.5 | 23   | 18         |    |
| 20         |       | 66   | 65     | 66.2  | 66.2  | 59.4  | 54   | 49.5 | 45.2 | 39.2 | 36   | 32   | 29   | 21.5 | 20         |    |
| 22         |       |      | 57     | 55.5  | 55.5  | 54    | 48   | 45   | 41.5 | 36.2 | 33   | 29.5 | 27   | 20   | 22         |    |
| 24         |       |      | 51     | 48    | 47    | 47.9  | 43.8 | 40   | 38   | 33.5 | 31   | 27.5 | 25   | 18   | 24         |    |
| 26         |       |      |        | 42    | 40    | 42    | 40.8 | 36   | 34.2 | 30.8 | 28.5 | 25.5 | 23.5 | 17   | 26         |    |
| 28         |       |      |        | 37    | 36    | 36.8  | 37.8 | 33   | 31.8 | 28.2 | 27   | 24   | 22   | 16   | 28         |    |
| 30         |       |      |        | 32    | 32    | 31.8  | 34.5 | 30.8 | 29.2 | 26   | 24.5 | 22   | 20.5 | 14.5 | 30         |    |
| 32         |       |      |        |       | 28    | 29    | 31.6 | 28   | 27.2 | 24.2 | 22.5 | 20.5 | 19.5 | 13.4 | 32         |    |
| 34         |       |      |        |       | 25    | 26    | 28.4 | 25.3 | 25   | 22.2 | 21   | 19   | 17.5 | 12   | 34         |    |
| 36         |       |      |        |       |       | 24    | 26   | 22   | 23   | 20.2 | 19   | 17.5 | 16   | 11   | 36         |    |
| 38         |       |      |        |       |       | 21    | 23   | 19.1 | 20.9 | 18.4 | 18   | 16.5 | 15   | 10   | 38         |    |
| 40         |       |      |        |       |       | 19    | 20.6 | 17.4 | 18.4 | 16.6 | 16.5 | 15   | 14   | 9    | 40         |    |
| 42         |       |      |        |       |       |       | 18   | 15.9 | 16.1 | 15.2 | 15.2 | 14   | 13   | 8    | 42         |    |
| 44         |       |      |        |       |       |       | 15.8 | 14.5 | 14.3 | 14   | 14   | 13   | 12   | 7    | 44         |    |
| 46         |       |      |        |       |       |       |      |      | 13.2 | 13.1 | 13   | 12.8 | 12   | 11   | 6          | 46 |
| 48         |       |      |        |       |       |       |      |      | 11.8 | 11.9 | 11.5 | 11.5 | 11   | 10   | 5.5        | 48 |
| 50         |       |      |        |       |       |       |      |      | 10   | 10.8 | 10   | 10.2 | 10   | 9    | 5          | 50 |
| 52         |       |      |        |       |       |       |      |      |      | 9.6  | 8.5  | 9.5  | 9.5  | 8.5  | 4.2        | 52 |
| 54         |       |      |        |       |       |       |      |      |      | 8.5  | 7.8  | 8.8  | 9    | 8    | 3.8        | 54 |
| 56         |       |      |        |       |       |       |      |      |      | 6    | 7.2  | 7.6  | 8    | 7.2  | 3.5        | 56 |
| 58         |       |      |        |       |       |       |      |      |      |      | 6.6  | 6.5  | 7.5  | 6.8  | 3.2        | 58 |
| 60         |       |      |        |       |       |       |      |      |      |      |      | 5.8  | 6.5  | 6    | 3          | 60 |
| 62         |       |      |        |       |       |       |      |      |      |      |      |      | 5.3  | 5.5  | 2.5        | 62 |
| 64         |       |      |        |       |       |       |      |      |      |      |      |      |      | 4.8  | 2          | 64 |
| 66         |       |      |        |       |       |       |      |      |      |      |      |      |      | 4.5  | 4.5        | 66 |
| 68         |       |      |        |       |       |       |      |      |      |      |      |      |      | 4    | 4.2        | 68 |
| 70         |       |      |        |       |       |       |      |      |      |      |      |      |      | 3.8  | 3.8        | 70 |
| 72         |       |      |        |       |       |       |      |      |      |      |      |      |      |      | 3.3        | 72 |
| 74         |       |      |        |       |       |       |      |      |      |      |      |      |      |      | 3          | 74 |

Notes: The item with \* should be operated at rear side with additional equipment.

# Load Chart - Telescopic Boom

Unit: t

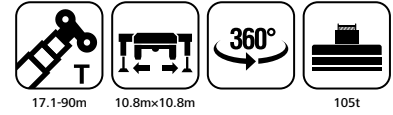

| Radius (m) | 17.1 | 22.7 | 28.3   | 33.9  | 39.5  | 45    | 50.6 | 56.2 | 61.8 | 67.4 | 73   | 78.6 | 84.2 | 90   | Radius (m) |
|------------|------|------|--------|-------|-------|-------|------|------|------|------|------|------|------|------|------------|
| 3          | 263  |      |        |       |       |       |      |      |      |      |      |      |      |      | 3          |
| 3.5        | 263  | 263  |        |       |       |       |      |      |      |      |      |      |      |      | 3.5        |
| 4          | 263  | 263  | 260.4  |       |       |       |      |      |      |      |      |      |      |      | 4          |
| 4.5        | 256  | 262  | 245    |       |       |       |      |      |      |      |      |      |      |      | 4.5        |
| 5          | 240  | 241  | 240.45 | 212   |       |       |      |      |      |      |      |      |      |      | 5          |
| 6          | 216  | 218  | 218.4  | 200.4 | 174   |       |      |      |      |      |      |      |      |      | 6          |
| 7          | 191  | 188  | 199.5  | 187.2 | 159.6 | 139.2 |      |      |      |      |      |      |      |      | 7          |
| 8          | 170  | 168  | 170    | 169.8 | 147.6 | 128.4 | 112  |      |      |      |      |      |      |      | 8          |
| 9          | 154  | 150  | 155    | 154   | 136.8 | 120   | 105  | 87.6 |      |      |      |      |      |      | 9          |
| 10         | 140  | 135  | 143    | 140.4 | 127.2 | 112.8 | 98   | 82.8 | 72   |      |      |      |      |      | 10         |
| 12         | 114  | 112  | 120    | 118.5 | 110.4 | 99.6  | 87   | 75.6 | 64.5 | 55.8 | 49   |      |      |      | 12         |
| 14         | 95   | 93   | 96     | 101.7 | 96    | 87.6  | 76   | 68.4 | 59   | 51.6 | 45.6 | 40   |      |      | 14         |
| 16         |      | 79   | 82     | 88    | 85.2  | 75.6  | 68.4 | 62   | 54   | 46.8 | 42   | 37   | 32.5 | 25   | 16         |
| 18         |      | 70.8 | 72     | 75    | 70    | 66    | 60   | 55   | 49.5 | 43   | 39   | 34.5 | 30.5 | 23   | 18         |
| 20         |      | 66   | 61     | 63.9  | 62.4  | 58    | 54   | 49.5 | 45.2 | 39.2 | 36   | 32   | 29   | 21   | 20         |
| 22         |      |      | 50     | 53.5  | 52.1  | 50    | 48   | 45   | 41.5 | 36.2 | 33   | 29.5 | 27   | 20   | 22         |
| 24         |      |      | 41     | 45.2  | 43.8  | 44    | 43.8 | 40   | 38   | 33.5 | 31   | 27.5 | 25   | 18   | 24         |
| 26         |      |      |        | 38.4  | 37    | 39.4  | 38.8 | 36   | 34.2 | 30.8 | 28.5 | 25.5 | 23.5 | 17   | 26         |
| 28         |      |      |        | 32.7  | 31.4  | 33.7  | 34   | 32   | 31.8 | 28.2 | 27   | 24   | 22   | 16   | 28         |
| 30         |      |      |        | 28    | 26.6  | 28.9  | 30   | 29.3 | 29.2 | 26   | 24.5 | 22   | 20.5 | 14.5 | 30         |
| 32         |      |      |        |       | 22.8  | 24.8  | 26.5 | 25.2 | 25   | 24.2 | 22.5 | 20.5 | 19.5 | 13.4 | 32         |
| 34         |      |      |        |       | 20    | 21.7  | 23.5 | 21.6 | 23.4 | 22.2 | 21   | 19   | 17.5 | 12   | 34         |
| 36         |      |      |        |       |       | 19    | 20.8 | 18.6 | 20.2 | 18   | 19   | 17.5 | 16   | 11   | 36         |
| 38         |      |      |        |       |       | 17    | 18.5 | 16.4 | 17.5 | 17   | 18   | 16.5 | 15   | 10   | 38         |
| 40         |      |      |        |       |       | 15    | 16.4 | 15.2 | 15.3 | 15.9 | 16.5 | 15   | 14   | 9    | 40         |
| 42         |      |      |        |       |       |       | 14.6 | 14   | 13.5 | 13.7 | 14   | 14   | 13   | 8    | 42         |
| 44         |      |      |        |       |       |       | 12.9 | 13   | 12.2 | 12.1 | 13   | 13   | 12   | 7    | 44         |
| 46         |      |      |        |       |       |       | 11   | 12   | 11   | 10.8 | 11.6 | 12.6 | 11   | 6    | 46         |
| 48         |      |      |        |       |       |       |      | 11   | 9.8  | 10   | 9.9  | 11   | 10   | 5.5  | 48         |
| 50         |      |      |        |       |       |       |      | 10   | 8.9  | 9.2  | 8.9  | 9.5  | 9    | 5    | 50         |
| 52         |      |      |        |       |       |       |      |      | 7.8  | 8.2  | 7.9  | 8.1  | 8.5  | 4.2  | 52         |
| 54         |      |      |        |       |       |       |      |      | 6.9  | 7.8  | 6.7  | 7.5  | 8    | 3.8  | 54         |
| 56         |      |      |        |       |       |       |      |      | 6    | 7.2  | 5.6  | 6.5  | 6.7  | 3.5  | 56         |
| 58         |      |      |        |       |       |       |      |      |      | 6.6  | 5    | 6.2  | 6.3  | 3.2  | 58         |
| 60         |      |      |        |       |       |       |      |      |      |      | 4.5  | 5.5  | 5.2  | 2.8  | 60         |
| 62         |      |      |        |       |       |       |      |      |      |      |      | 4    | 4.6  | 2.5  | 62         |
| 64         |      |      |        |       |       |       |      |      |      |      |      |      | 4    | 2    | 64         |
| 66         |      |      |        |       |       |       |      |      |      |      |      |      |      |      | 66         |

# Load Chart - Telescopic Boom

Unit: t

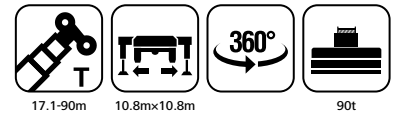

| Radius (m) | 17.1 | 22.7 | 28.3  | 33.9  | 39.5  | 45    | 50.6 | 56.2 | 61.8 | 67.4 | 73   | 78.6 | 84.2 | 90   | Radius (m) |
|------------|------|------|-------|-------|-------|-------|------|------|------|------|------|------|------|------|------------|
| 3          | 263  |      |       |       |       |       |      |      |      |      |      |      |      |      | 3          |
| 3.5        | 263  | 263  |       |       |       |       |      |      |      |      |      |      |      |      | 3.5        |
| 4          | 263  | 263  | 230   |       |       |       |      |      |      |      |      |      |      |      | 4          |
| 4.5        | 256  | 262  | 230   |       |       |       |      |      |      |      |      |      |      |      | 4.5        |
| 5          | 240  | 241  | 223   | 219.6 |       |       |      |      |      |      |      |      |      |      | 5          |
| 6          | 216  | 218  | 218.4 | 201.6 | 174   |       |      |      |      |      |      |      |      |      | 6          |
| 7          | 191  | 188  | 199.5 | 187.2 | 159.6 | 139.2 |      |      |      |      |      |      |      |      | 7          |
| 8          | 170  | 168  | 170   | 171.6 | 147.6 | 128.4 | 112  |      |      |      |      |      |      |      | 8          |
| 9          | 154  | 150  | 155   | 158.4 | 136.8 | 120   | 105  | 87.6 |      |      |      |      |      |      | 9          |
| 10         | 136  | 135  | 143   | 146.4 | 127.2 | 112.8 | 98   | 82.8 | 72   |      |      |      |      |      | 10         |
| 12         | 108  | 112  | 120   | 115   | 110.4 | 99.6  | 87   | 75.6 | 64.5 | 55.8 | 49   |      |      |      | 12         |
| 14         | 90   | 93   | 96    | 96    | 96    | 87.6  | 76   | 68.4 | 59   | 51.6 | 45.6 | 40   |      |      | 14         |
| 16         |      | 79   | 81.2  | 83    | 81.4  | 75.6  | 68.4 | 62   | 54   | 46.8 | 42   | 37   | 32.5 | 25   | 16         |
| 18         |      | 70.8 | 65.2  | 66.9  | 65.4  | 65.6  | 60   | 55   | 49.5 | 43   | 39   | 34.5 | 30.5 | 23   | 18         |
| 20         |      | 62.5 | 53.2  | 54.9  | 53.4  | 55.8  | 54   | 49.5 | 45.2 | 39.2 | 36   | 32   | 29   | 21.5 | 20         |
| 22         |      |      | 44.4  | 45.6  | 44.1  | 46.5  | 45.3 | 45   | 41.5 | 36.2 | 33   | 29.5 | 27   | 20   | 22         |
| 24         |      |      | 40.8  | 38    | 36.6  | 39    | 38.8 | 39.4 | 38   | 33.5 | 31   | 27.5 | 25   | 18   | 24         |
| 26         |      |      |       | 32.5  | 30.5  | 32.9  | 33.6 | 33.2 | 34.2 | 30.8 | 28.5 | 25.5 | 23.5 | 17   | 26         |
| 28         |      |      |       | 28.1  | 26.3  | 27.8  | 29.2 | 28.1 | 31.8 | 28.2 | 27   | 24   | 22   | 16   | 28         |
| 30         |      |      |       | 24.7  | 24    | 24.6  | 25.5 | 24.1 | 28.2 | 26   | 24.5 | 22   | 20.5 | 14.5 | 30         |
| 32         |      |      |       |       | 22.2  | 21.5  | 22.4 | 21   | 24.4 | 22.8 | 22.5 | 20.5 | 19.5 | 13.4 | 32         |
| 34         |      |      |       |       | 20    | 18.8  | 19.6 | 18.5 | 21.2 | 19.5 | 21   | 19   | 17.5 | 12   | 34         |
| 36         |      |      |       |       |       | 17.2  | 17.3 | 17.2 | 18.3 | 17.4 | 18.3 | 17.5 | 16   | 11   | 36         |
| 38         |      |      |       |       |       | 16    | 15.8 | 16.2 | 15.8 | 15.4 | 15.8 | 16.5 | 15   | 10   | 38         |
| 40         |      |      |       |       |       | 15    | 14   | 15.2 | 14.5 | 13.5 | 14   | 14.6 | 14   | 9    | 40         |
| 42         |      |      |       |       |       |       | 13   | 14   | 13.2 | 12   | 12.8 | 12.6 | 13   | 8    | 42         |
| 44         |      |      |       |       |       |       | 12   | 13   | 12.2 | 11.2 | 11.2 | 11   | 12   | 7    | 44         |
| 46         |      |      |       |       |       |       | 11   | 12   | 10.8 | 10.4 | 9.7  | 10.1 | 10.4 | 6    | 46         |
| 48         |      |      |       |       |       |       |      | 11   | 9.3  | 10   | 8.3  | 9.1  | 8.9  | 5.5  | 48         |
| 50         |      |      |       |       |       |       |      | 10   | 8    | 9.2  | 7.2  | 8.5  | 8.1  | 5    | 50         |
| 52         |      |      |       |       |       |       |      |      | 7.2  | 8.2  | 6.5  | 7.5  | 7.5  | 4.2  | 52         |
| 54         |      |      |       |       |       |       |      |      | 6.4  | 7.8  | 6    | 6.4  | 6.3  | 3.8  | 54         |
| 56         |      |      |       |       |       |       |      |      | 5.5  | 7.2  | 5.5  | 6    | 5.2  | 3.5  | 56         |
| 58         |      |      |       |       |       |       |      |      |      | 6.6  | 5    | 5.6  | 4.5  | 3.2  | 58         |
| 60         |      |      |       |       |       |       |      |      |      | 4    | 4.5  | 5.1  | 4    | 2.5  | 60         |
| 62         |      |      |       |       |       |       |      |      |      |      | 3.9  | 4.5  | 3    | 2.2  | 62         |
| 64         |      |      |       |       |       |       |      |      |      |      | 3.5  | 3    |      | 1.5  | 64         |
| 66         |      |      |       |       |       |       |      |      |      |      | 3.2  |      |      |      | 66         |

# Load Chart - Telescopic Boom

Unit: t

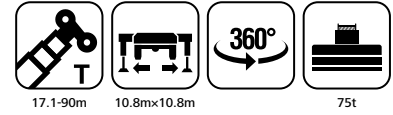

| Radius (m) | 17.1 | 22.7 | 28.3   | 33.9  | 39.5  | 45    | 50.6 | 56.2 | 61.8 | 67.4 | 73   | 78.6 | 84.2 | 90   | Radius (m) |
|------------|------|------|--------|-------|-------|-------|------|------|------|------|------|------|------|------|------------|
| 3          | 263  |      |        |       |       |       |      |      |      |      |      |      |      |      | 3          |
| 3.5        | 263  | 263  |        |       |       |       |      |      |      |      |      |      |      |      | 3.5        |
| 4          | 263  | 263  | 260.4  |       |       |       |      |      |      |      |      |      |      |      | 4          |
| 4.5        | 256  | 262  | 250.95 |       |       |       |      |      |      |      |      |      |      |      | 4.5        |
| 5          | 240  | 241  | 240.45 | 219.6 |       |       |      |      |      |      |      |      |      |      | 5          |
| 6          | 218  | 216  | 218.4  | 200.4 | 174   |       |      |      |      |      |      |      |      |      | 6          |
| 7          | 186  | 196  | 199.5  | 187.2 | 159.6 | 139.2 |      |      |      |      |      |      |      |      | 7          |
| 8          | 160  | 179  | 178.5  | 169.8 | 147.6 | 128.4 | 112  |      |      |      |      |      |      |      | 8          |
| 9          | 142  | 158  | 160    | 154   | 136.8 | 120   | 105  | 87.6 |      |      |      |      |      |      | 9          |
| 10         | 130  | 140  | 140    | 140.4 | 127.2 | 112.8 | 98   | 82.8 | 72   |      |      |      |      |      | 10         |
| 12         | 102  | 104  | 110    | 112   | 110.4 | 99.6  | 87   | 75.6 | 64.5 | 55.8 | 49   |      |      |      | 12         |
| 14         | 86   | 85   | 89.2   | 91.1  | 89.4  | 87.6  | 76   | 68.4 | 59   | 51.6 | 45.6 | 40   |      |      | 14         |
| 16         |      | 76.8 | 69.3   | 71    | 69.5  | 69.6  | 68.4 | 62   | 54   | 46.8 | 42   | 37   | 32.5 | 25   | 16         |
| 18         |      | 64.6 | 55     | 56.7  | 55.2  | 57.7  | 56.4 | 55   | 49.5 | 43   | 39   | 34.5 | 30.5 | 23   | 18         |
| 20         |      | 53.6 | 48     | 46    | 44.5  | 47    | 46   | 47.3 | 45.2 | 39.2 | 36   | 32   | 29   | 21.5 | 20         |
| 22         |      |      | 44.4   | 38.5  | 37    | 39    | 38.8 | 38.9 | 41.5 | 36.2 | 33   | 29.5 | 27   | 20   | 22         |
| 24         |      |      | 40.8   | 33    | 31.5  | 33    | 33.1 | 32.2 | 34   | 33.5 | 31   | 27.5 | 25   | 18   | 24         |
| 26         |      |      |        | 30.2  | 28    | 28.6  | 28.4 | 26.9 | 28.5 | 29.5 | 28.5 | 25.5 | 23.5 | 17   | 26         |
| 28         |      |      |        | 28    | 26    | 24.3  | 24.5 | 23.2 | 24   | 24.9 | 26.6 | 24   | 22   | 16   | 28         |
| 30         |      |      |        | 25    | 24    | 21    | 22   | 21   | 21.8 | 21.1 | 22.7 | 22   | 20.5 | 14.5 | 30         |
| 32         |      |      |        |       | 22.2  | 20    | 20   | 19.8 | 19.8 | 18.4 | 19.3 | 20.4 | 19.5 | 13.4 | 32         |
| 34         |      |      |        |       | 20    | 18.5  | 18.8 | 18.5 | 18.5 | 16.8 | 16.9 | 17.5 | 17.5 | 12   | 34         |
| 36         |      |      |        |       |       | 17.2  | 17   | 17.2 | 16.6 | 15.2 | 14.9 | 16   | 16   | 10.8 | 36         |
| 38         |      |      |        |       |       | 16    | 15.8 | 16.2 | 14.3 | 14.2 | 13   | 14.5 | 13.9 | 9.8  | 38         |
| 40         |      |      |        |       |       | 15    | 14   | 15.2 | 12.4 | 13   | 12   | 13   | 12   | 8.8  | 40         |
| 42         |      |      |        |       |       |       | 12.4 | 14   | 11.4 | 12   | 11   | 11.3 | 11.2 | 7.9  | 42         |
| 44         |      |      |        |       |       |       | 11   | 13   | 10.4 | 11.2 | 10   | 9.7  | 9.9  | 7.2  | 44         |
| 46         |      |      |        |       |       |       |      | 12   | 9.8  | 10.4 | 9.2  | 8.9  | 8.7  | 6    | 46         |
| 48         |      |      |        |       |       |       |      | 10.7 | 8.8  | 9.1  | 8    | 8.1  | 7.6  | 5.5  | 48         |
| 50         |      |      |        |       |       |       |      | 9.4  | 7.8  | 8    | 7    | 7.4  | 6.4  | 4.5  | 50         |
| 52         |      |      |        |       |       |       |      |      | 7.2  | 7.4  | 5.9  | 6.9  | 5.2  | 3.8  | 52         |
| 54         |      |      |        |       |       |       |      |      | 6.4  | 6.9  | 5.4  | 5.9  | 4    | 3.5  | 54         |
| 56         |      |      |        |       |       |       |      |      | 5.8  | 6.4  | 5    | 4    | 3    | 3    | 56         |
| 58         |      |      |        |       |       |       |      |      |      | 5.9  | 4.6  | 3    |      |      | 58         |
| 60         |      |      |        |       |       |       |      |      |      |      | 4.2  |      |      |      | 60         |
| 62         |      |      |        |       |       |       |      |      |      |      | 3    |      |      |      | 62         |

# Boom Operating Range

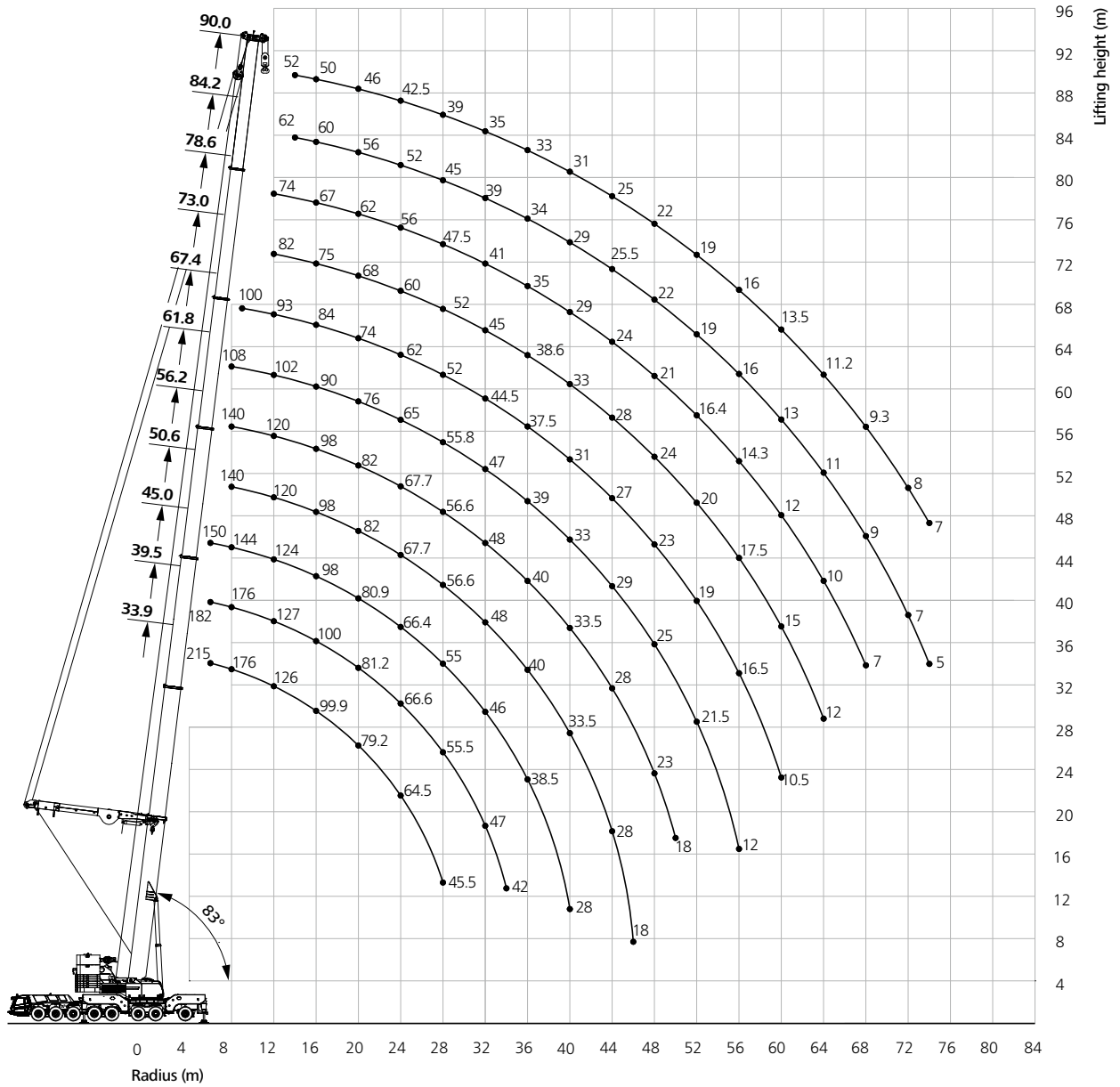

# Load Chart - Telescopic Boom

Unit: t

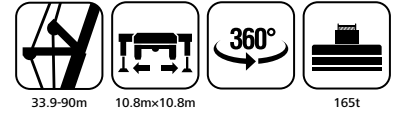

| Radius (m) | 33.9  | 39.5  | 45    | 50.6  | 56.2 | 61.8 | 67.4 | 73   | 78.6 | 84.2 | 90   | Radius (m) |
|------------|-------|-------|-------|-------|------|------|------|------|------|------|------|------------|
| 4.5        | 225   |       |       |       |      |      |      |      |      |      |      | 4.5        |
| 5          | 220   |       |       |       |      |      |      |      |      |      |      | 5          |
| 6          | 215   | 182   | 150   | 149.5 |      |      |      |      |      |      |      | 6          |
| 7          | 195.2 | 180   | 148   | 146   |      |      |      |      |      |      |      | 7          |
| 8          | 176.5 | 176.3 | 144   | 142   | 127  | 108  |      |      |      |      |      | 8          |
| 9          | 160.6 | 160.5 | 136   | 136   | 125  | 106  | 100  |      |      |      |      | 9          |
| 10         | 147   | 146.9 | 130   | 132   | 122  | 105  | 97   |      |      |      |      | 10         |
| 12         | 125.8 | 126.8 | 124   | 122   | 115  | 102  | 93   | 82   | 74   |      |      | 12         |
| 14         | 112   | 112   | 107.8 | 110   | 103  | 97   | 87   | 79   | 70   | 62   | 52   | 14         |
| 16         | 99.9  | 100   | 98    | 98    | 94   | 90   | 84   | 75   | 67   | 60   | 50   | 16         |
| 18         | 88.6  | 90.5  | 90    | 89.5  | 86   | 84   | 79   | 72   | 65   | 58   | 48   | 18         |
| 20         | 79.2  | 81.2  | 80.9  | 82    | 80   | 76   | 74   | 68   | 62   | 56   | 46   | 20         |
| 22         | 71.3  | 73.3  | 73.1  | 74.4  | 73   | 70   | 68   | 63   | 59   | 54   | 44   | 22         |
| 24         | 64.5  | 66.6  | 66.4  | 67.7  | 66   | 65   | 62   | 60   | 56   | 52   | 42.5 | 24         |
| 26         | 58.6  | 60.7  | 60    | 61.9  | 59.6 | 60   | 58   | 56   | 52   | 49   | 40.5 | 26         |
| 28         | 53.4  | 55.5  | 55    | 56.6  | 54.6 | 55.8 | 52   | 52   | 47.5 | 45   | 39   | 28         |
| 30         | 42    | 51    | 50    | 52    | 50   | 51   | 48   | 48   | 44   | 42   | 37   | 30         |
| 32         |       | 47    | 46    | 48    | 45.5 | 47   | 44.5 | 45   | 41   | 39   | 35   | 32         |
| 34         |       | 42    | 42    | 44    | 42   | 42.5 | 40.5 | 41.6 | 38   | 36.5 | 34   | 34         |
| 36         |       |       | 38.5  | 40    | 39   | 39   | 37.5 | 38.6 | 35   | 34   | 33   | 36         |
| 38         |       |       | 35.5  | 36.5  | 35   | 36   | 35   | 35.6 | 32   | 31.5 | 32   | 38         |
| 40         |       |       | 28    | 33.5  | 32   | 33   | 31   | 33   | 29   | 29   | 31   | 40         |
| 42         |       |       |       | 31.5  | 30   | 31   | 29.5 | 30   | 26   | 27   | 28   | 42         |
| 44         |       |       |       | 28    | 28   | 29   | 27   | 28   | 24   | 25.5 | 25   | 44         |
| 46         |       |       |       | 18    | 26   | 27   | 25   | 26   | 22   | 24   | 24   | 46         |
| 48         |       |       |       |       | 23   | 25   | 23   | 24   | 21   | 22   | 22   | 48         |
| 50         |       |       |       |       | 18   | 23   | 21   | 22   | 18.5 | 20   | 20.4 | 50         |
| 52         |       |       |       |       |      | 21.5 | 19   | 20   | 16.4 | 19   | 19   | 52         |
| 54         |       |       |       |       |      | 18.5 | 17.5 | 18.5 | 15.3 | 17   | 17.2 | 54         |
| 56         |       |       |       |       |      | 12   | 16.5 | 17.5 | 14.3 | 16   | 16   | 56         |
| 58         |       |       |       |       |      |      | 14.5 | 16.5 | 13   | 14   | 14.3 | 58         |
| 60         |       |       |       |       |      |      | 10.5 | 15   | 12   | 13   | 13.5 | 60         |
| 62         |       |       |       |       |      |      |      | 14   | 11   | 12   | 12.4 | 62         |
| 64         |       |       |       |       |      |      |      | 12   | 10   | 11   | 11.2 | 64         |
| 66         |       |       |       |       |      |      |      |      | 9    | 10   | 10.5 | 66         |
| 68         |       |       |       |       |      |      |      |      | 7    | 9    | 9.3  | 68         |
| 70         |       |       |       |       |      |      |      |      |      | 8    | 8.4  | 70         |
| 72         |       |       |       |       |      |      |      |      |      | 7    | 8    | 72         |
| 74         |       |       |       |       |      |      |      |      |      | 5    | 7    | 74         |
| 76         |       |       |       |       |      |      |      |      |      |      | 6    | 76         |
| 78         |       |       |       |       |      |      |      |      |      |      |      | 78         |

# Load Chart - Telescopic Boom

Unit: t

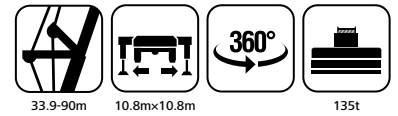

| Radius (m) | 33.9  | 39.5  | 45    | 50.6  | 56.2 | 61.8 | 67.4 | 73   | 78.6 | 84.2 | 90   | Radius (m) |
|------------|-------|-------|-------|-------|------|------|------|------|------|------|------|------------|
| 4.5        | 225   | 190   | 138   |       |      |      |      |      |      |      |      | 4.5        |
| 5          | 220   | 185   | 152   | 152   |      |      |      |      |      |      |      | 5          |
| 6          | 213.7 | 182   | 150   | 149.5 | 134  | 110  |      |      |      |      |      | 6          |
| 7          | 191.6 | 180   | 148   | 146   | 130  | 110  | 100  |      |      |      |      | 7          |
| 8          | 173.2 | 173   | 144   | 142   | 127  | 108  | 100  |      |      |      |      | 8          |
| 9          | 157.6 | 157.5 | 136   | 136   | 125  | 106  | 100  | 84   |      |      |      | 9          |
| 10         | 144   | 143.9 | 130   | 132   | 122  | 105  | 97   | 84   | 74   | 62   | 52   | 10         |
| 12         | 122.5 | 123.6 | 122.1 | 122   | 115  | 102  | 93   | 82   | 74   | 62   | 52   | 12         |
| 14         | 109.3 | 109.2 | 104.9 | 108   | 103  | 97   | 87   | 79   | 70   | 62   | 52   | 14         |
| 16         | 97.3  | 97.7  | 96.7  | 96    | 94   | 90   | 84   | 75   | 67   | 60   | 50   | 16         |
| 18         | 86.3  | 88.1  | 87.9  | 87.2  | 85.3 | 84   | 79   | 72   | 65   | 58   | 48   | 18         |
| 20         | 77.1  | 79    | 78.8  | 80.1  | 79   | 76   | 74   | 68   | 62   | 56   | 46   | 20         |
| 22         | 69.3  | 71.3  | 71.1  | 72.4  | 71.3 | 70   | 68   | 63   | 59   | 54   | 44   | 22         |
| 24         | 62.3  | 64.7  | 64.5  | 65.9  | 64.7 | 65   | 62   | 60   | 56   | 52   | 42.5 | 24         |
| 26         | 55.7  | 58.2  | 58    | 59.5  | 58.2 | 59.4 | 55   | 55   | 50   | 49   | 40.5 | 26         |
| 28         | 50    | 52.5  | 52.3  | 53.9  | 52.6 | 53.9 | 50   | 50   | 46   | 45   | 39   | 28         |
| 30         | 42    | 47.6  | 47.5  | 49.1  | 47.8 | 49   | 46   | 46   | 42   | 42   | 37   | 30         |
| 32         |       | 43.3  | 43.2  | 44.8  | 43.5 | 44.8 | 42   | 42   | 38   | 39   | 35   | 32         |
| 34         |       | 39.5  | 39.5  | 41.1  | 38   | 40   | 38   | 38   | 35   | 35   | 34   | 34         |
| 36         |       |       | 35    | 37.8  | 35   | 36   | 34   | 35   | 32   | 32   | 32   | 36         |
| 38         |       |       | 33.1  | 34.8  | 32   | 33   | 31   | 32   | 29   | 30   | 29   | 38         |
| 40         |       |       | 28    | 31    | 30   | 31   | 28   | 30   | 26   | 27   | 26.5 | 40         |
| 42         |       |       |       | 29    | 27   | 28   | 26   | 27   | 24   | 25   | 25   | 42         |
| 44         |       |       |       | 26    | 25   | 26   | 24   | 25   | 22   | 23   | 23   | 44         |
| 46         |       |       |       | 18    | 22.5 | 24   | 22   | 23   | 20   | 21   | 21   | 46         |
| 48         |       |       |       |       | 21   | 22   | 20   | 21   | 18   | 19   | 19   | 48         |
| 50         |       |       |       |       | 18   | 20   | 18   | 19   | 16   | 17   | 17   | 50         |
| 52         |       |       |       |       |      | 19   | 16   | 17.5 | 14.5 | 15.5 | 15.5 | 52         |
| 54         |       |       |       |       |      | 17   | 15   | 16   | 13   | 14   | 14   | 54         |
| 56         |       |       |       |       |      | 12   | 13   | 15   | 12   | 12.5 | 12.5 | 56         |
| 58         |       |       |       |       |      |      | 12.5 | 13.5 | 10.7 | 11.5 | 11.5 | 58         |
| 60         |       |       |       |       |      |      |      | 10.5 | 9.4  | 10.8 | 10.5 | 60         |
| 62         |       |       |       |       |      |      |      |      | 11.5 | 8.1  | 9.6  | 62         |
| 64         |       |       |       |       |      |      |      |      | 10.3 | 6.9  | 8.4  | 64         |
| 66         |       |       |       |       |      |      |      |      |      | 5.8  | 7.3  | 66         |
| 68         |       |       |       |       |      |      |      |      |      | 4.7  | 6.2  | 68         |
| 70         |       |       |       |       |      |      |      |      |      |      | 5.2  | 70         |
| 72         |       |       |       |       |      |      |      |      |      |      | 4.3  | 72         |
| 74         |       |       |       |       |      |      |      |      |      |      | 3.4  | 74         |
| 76         |       |       |       |       |      |      |      |      |      |      | 3    | 76         |

# Jib Operating Range

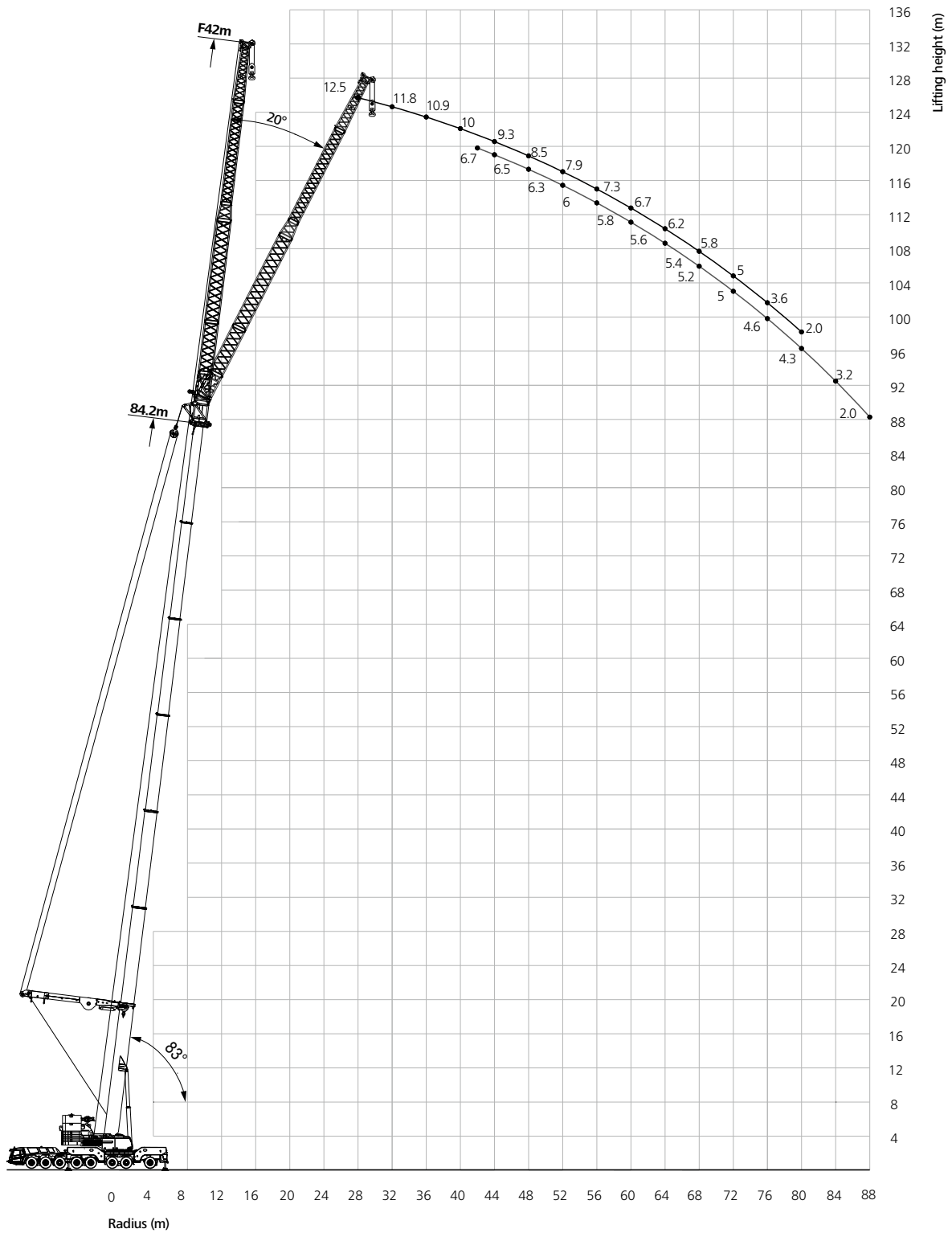

# Load Chart - Fixed Jib

Unit: t

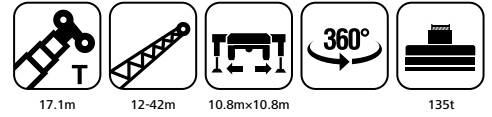

| Radius (m) | 12m  |      |      | 18m  |      |      | 24m  |      |      | 30m  |      |     | 36m  |      |     | 42m  |     | Radius (m) |
|------------|------|------|------|------|------|------|------|------|------|------|------|-----|------|------|-----|------|-----|------------|
|            | 0°   | 20°  | 40°  | 0°   | 20°  | 40°  | 0°   | 20°  | 40°  | 0°   | 20°  | 40° | 0°   | 20°  | 40° | 0°   | 20° |            |
| 5          | 73   |      |      |      |      |      |      |      |      |      |      |     |      |      |     |      |     | 5          |
| 6          | 65   |      |      | 50   |      |      |      |      |      |      |      |     |      |      |     |      |     | 6          |
| 7          | 58   |      |      | 45.5 |      |      | 49.1 |      |      | 38.0 |      |     |      |      |     |      |     | 7          |
| 8          | 52   |      |      | 41   |      |      | 44.2 |      |      | 35.0 |      |     | 28.7 |      |     |      |     | 8          |
| 9          | 45.5 |      |      | 37.5 |      |      | 40.4 |      |      | 32.4 |      |     | 26.4 |      |     | 22.4 |     | 9          |
| 10         | 41   | 29.5 |      | 34   |      |      | 36.7 |      |      | 29.6 |      |     | 24.5 |      |     | 20.7 |     | 10         |
| 12         | 35.5 | 25.9 |      | 28.2 |      |      | 30.4 |      |      | 25.1 |      |     | 21.1 |      |     | 18   |     | 12         |
| 14         | 31   | 23   | 19.1 | 24.7 | 18.5 |      | 26.6 | 19.1 |      | 21.7 |      |     | 18.3 |      |     | 15.8 |     | 14         |
| 16         | 26.8 | 20.8 | 17.6 | 21.8 | 16.5 |      | 23.5 | 18.0 |      | 19.1 | 14.0 |     | 15.9 |      |     | 13.9 |     | 16         |
| 18         | 23.2 | 18.9 | 16.2 | 19.3 | 14.8 |      | 20.8 | 16.1 |      | 17.0 | 12.7 |     | 14.3 |      |     | 12.2 |     | 18         |
| 20         | 19.9 | 17.2 | 15.2 | 17.1 | 13.5 | 11.7 | 18.4 | 14.7 | 12.2 | 15.3 | 11.4 |     | 12.9 | 10.0 |     | 11   |     | 20         |
| 22         | 17.7 | 15.7 | 14.3 | 15   | 12.3 | 10.8 | 16.2 | 13.4 | 11.8 | 13.6 | 10.3 |     | 11.6 | 9.0  |     | 10   |     | 22         |
| 24         | 16.1 | 14.5 | 13.5 | 13.1 | 11.3 | 10   | 14.1 | 12.3 | 10.9 | 12.1 | 9.4  | 8.0 | 10.4 | 8.1  |     | 9.1  | 6.8 | 24         |
| 26         | 14.6 | 13.5 | 13   | 11.5 | 10.4 | 9.4  | 12.4 | 11.3 | 10.2 | 10.7 | 8.7  | 7.5 | 9.4  | 7.3  |     | 8.3  | 6.2 | 26         |
| 28         | 13.4 | 12.9 |      | 10.5 | 9.5  | 8.9  | 11.3 | 10.3 | 9.7  | 9.4  | 7.9  | 6.9 | 8.4  | 6.6  |     | 7.5  | 5.6 | 28         |
| 30         |      |      |      | 9.6  | 8.8  | 8.3  | 10.4 | 9.5  | 9.0  | 8.3  | 7.3  | 6.5 | 7.4  | 6.1  | 5.0 | 6.8  | 5   | 30         |
| 32         |      |      |      | 8.8  | 8.2  | 8    | 9.5  | 8.9  | 8.7  | 7.4  | 6.7  | 6.1 | 6.5  | 5.7  | 4.6 | 6.1  | 4.6 | 32         |
| 34         |      |      |      | 8.1  | 7.8  |      | 8.7  | 8.4  | 8.3  | 6.8  | 6.1  | 5.6 | 5.6  | 5.2  | 4.3 | 5.4  | 4.2 | 34         |
| 36         |      |      |      |      |      |      | 8.1  | 8.0  |      | 6.3  | 5.6  | 5.3 | 5.1  | 4.8  | 4.1 | 4.8  | 3.9 | 36         |
| 38         |      |      |      |      |      |      | 7.6  |      |      | 5.7  | 5.3  | 5.1 | 4.7  | 4.4  | 3.8 | 4.1  | 3.6 | 38         |
| 40         |      |      |      |      |      |      |      |      |      | 5.2  | 5.0  | 4.9 | 4.4  | 4.1  | 3.6 | 3.7  | 3.3 | 40         |
| 42         |      |      |      |      |      |      |      |      |      | 4.9  | 4.8  |     | 4.0  | 3.8  | 3.4 | 3.3  | 3.1 | 42         |
| 44         |      |      |      |      |      |      |      |      |      | 4.6  | 4.6  |     | 3.7  | 3.6  | 3.2 | 3.1  | 2.8 | 44         |
| 46         |      |      |      |      |      |      |      |      |      |      |      |     | 3.4  | 3.3  | 3.1 | 2.8  | 2.6 | 46         |
| 48         |      |      |      |      |      |      |      |      |      |      |      |     | 3.2  | 3.2  | 3.0 | 2.6  |     | 48         |
| 50         |      |      |      |      |      |      |      |      |      |      |      |     | 3.0  | 3.0  |     | 2.4  |     | 50         |
| 52         |      |      |      |      |      |      |      |      |      |      |      |     |      |      |     |      |     | 52         |

# Load Chart - Fixed Jib

Unit: t

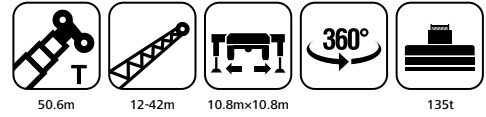

| Radius (m) | 12m  |      |      | 18m  |      |      | 24m  |      |      | 30m |     |     | 36m  |      |     | 42m  |     | Radius (m) |
|------------|------|------|------|------|------|------|------|------|------|-----|-----|-----|------|------|-----|------|-----|------------|
|            | 0°   | 20°  | 40°  | 0°   | 20°  | 40°  | 0°   | 20°  | 40°  | 0°  | 20° | 40° | 0°   | 20°  | 40° | 0°   | 20° |            |
| 12         | 44   |      |      | 32   |      |      | 32.5 |      |      |     |     |     |      |      |     |      |     | 12         |
| 14         | 40   |      |      | 29.4 |      |      | 30.7 |      |      |     |     |     | 23.5 |      |     | 18.3 |     | 14         |
| 16         | 37   | 25.3 |      | 27.2 |      |      | 28.4 |      |      |     |     |     | 21.9 |      |     | 16.8 |     | 16         |
| 18         | 34.5 | 23.8 |      | 25.2 | 17.2 |      | 26.3 | 18.0 |      |     |     |     | 20.2 |      |     | 15.6 |     | 18         |
| 20         | 32   | 22.5 | 17.5 | 23.4 | 16.2 |      | 24.4 | 17.3 |      |     |     |     | 18.9 |      |     | 14.5 |     | 20         |
| 22         | 30   | 21.3 | 16.9 | 21.8 | 15.3 |      | 22.7 | 16.3 |      |     |     |     | 17.6 | 12.5 |     | 13.6 |     | 22         |
| 24         | 28.3 | 20.2 | 16.3 | 20.4 | 14.4 | 11.3 | 21.3 | 15.3 | 12.1 |     |     |     | 16.4 | 11.8 |     | 12.7 |     | 24         |
| 26         | 26.7 | 19.2 | 15.8 | 19.3 | 13.7 | 10.8 | 20.1 | 14.5 | 11.6 |     |     |     | 15.3 | 11.2 |     | 11.8 | 8.4 | 26         |
| 28         | 24.9 | 18.4 | 15.3 | 18.3 | 12.9 | 10.4 | 19.1 | 13.7 | 11.1 |     |     |     | 14.5 | 10.5 |     | 11.0 | 7.9 | 28         |
| 30         | 23   | 17.7 | 14.8 | 17.3 | 12.3 | 10.1 | 18.1 | 13.0 | 10.8 |     |     |     | 13.8 | 9.9  | 7.2 | 10.4 | 7.4 | 30         |
| 32         | 21.3 | 17   | 14.5 | 16.5 | 11.8 | 9.7  | 17.2 | 12.5 | 10.3 |     |     |     | 13.0 | 9.4  | 6.9 | 9.8  | 7.0 | 32         |
| 34         | 19.6 | 16.3 | 14.1 | 15.6 | 11.3 | 9.4  | 16.3 | 11.9 | 10.0 |     |     |     | 12.3 | 8.9  | 6.6 | 9.3  | 6.6 | 34         |
| 36         | 18.1 | 15.7 | 13.8 | 14.8 | 10.8 | 9.1  | 15.4 | 11.4 | 9.7  |     |     |     | 11.7 | 8.5  | 6.4 | 8.8  | 6.2 | 36         |
| 38         | 16.5 | 15.1 | 13.5 | 13.9 | 10.4 | 8.9  | 14.5 | 11.0 | 9.4  |     |     |     | 11.2 | 8.0  | 6.2 | 8.4  | 5.9 | 38         |
| 40         | 14.9 | 14.6 | 13.2 | 13.2 | 10   | 8.6  | 13.8 | 10.5 | 9.1  |     |     |     | 10.6 | 7.7  | 5.9 | 8.0  | 5.6 | 40         |
| 42         | 13.4 | 13.8 | 13   | 12.4 | 9.6  | 8.4  | 12.9 | 10.1 | 8.9  |     |     |     | 10.0 | 7.4  | 5.7 | 7.6  | 5.4 | 42         |
| 44         | 12.1 | 12.7 | 12.8 | 11.7 | 9.2  | 8.2  | 12.2 | 9.7  | 8.7  |     |     |     | 9.3  | 7.1  | 5.6 | 7.2  | 5.1 | 44         |
| 46         | 11.1 | 11.6 | 12   | 10.9 | 8.9  | 8.1  | 11.4 | 9.4  | 8.6  |     |     |     | 8.8  | 6.8  | 5.5 | 6.8  | 4.9 | 46         |
| 48         | 10.1 | 10.6 |      | 9.9  | 8.6  | 7.9  | 10.3 | 9.0  | 8.3  |     |     |     | 8.2  | 6.5  | 5.3 | 6.4  | 4.7 | 48         |
| 50         | 9.3  | 9.6  |      | 9.1  | 8.3  | 7.7  | 9.5  | 8.7  | 8.1  |     |     |     | 7.7  | 6.2  | 5.2 | 6.0  | 4.5 | 50         |
| 52         | 8.4  | 8.7  |      | 8.3  | 8.0  | 7.6  | 8.7  | 8.4  | 8.0  |     |     |     | 7.2  | 6.0  | 5.1 | 5.7  | 4.3 | 52         |
| 54         | 7.3  | 7.9  |      | 7.6  | 7.8  | 7.6  | 7.9  | 8.2  | 8.0  |     |     |     | 6.8  | 5.7  | 4.9 | 5.3  | 4.1 | 54         |
| 56         | 5.9  | 6.3  |      | 7.0  | 7.4  |      | 7.3  | 7.8  |      |     |     |     | 6.5  | 5.5  | 4.8 | 4.9  | 3.9 | 56         |
| 58         | 4.5  |      |      | 5.8  | 6.7  |      | 6.6  | 7.0  |      |     |     |     | 6.2  | 5.2  | 4.7 | 4.6  | 3.7 | 58         |
| 60         | 3.3  |      |      | 4.6  | 5.5  |      | 5.5  | 6.4  |      |     |     |     | 5.9  | 5.1  | 4.7 | 4.3  | 3.6 | 60         |
| 62         |      |      |      | 3.4  | 4.1  |      | 4.4  | 5.8  |      |     |     |     | 5.2  | 5.0  |     | 4.2  | 3.4 | 62         |
| 64         |      |      |      | 2.3  | 2.8  |      | 3.3  | 4.6  |      |     |     |     | 4.1  | 4.8  |     | 3.9  | 3.3 | 64         |
| 66         |      |      |      |      |      |      | 2.2  |      |      |     |     |     | 3.0  | 4.7  |     | 3.1  | 3.2 | 66         |
| 68         |      |      |      |      |      |      |      |      |      |     |     |     | 2.1  | 3.7  |     | 2.1  | 3.1 | 68         |
| 70         |      |      |      |      |      |      |      |      |      |     |     |     | 2.6  |      |     | 3.0  | 2.9 | 70         |
| 72         |      |      |      |      |      |      |      |      |      |     |     |     |      |      |     | 2.3  | 2.8 | 72         |
| 74         |      |      |      |      |      |      |      |      |      |     |     |     |      |      |     | 2.0  |     | 74         |
| 76         |      |      |      |      |      |      |      |      |      |     |     |     |      |      |     |      | 1.6 | 76         |

# Load Chart - Fixed Jib

Unit: t

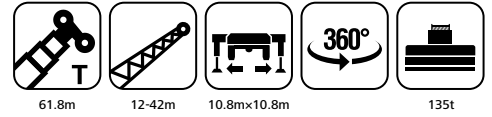

| Radius (m) | 12m  |      |      | 18m  |      |      | 24m  |      |      | 30m  |      |     | 36m  |     |     | 42m  |     | Radius (m) |
|------------|------|------|------|------|------|------|------|------|------|------|------|-----|------|-----|-----|------|-----|------------|
|            | 0°   | 20°  | 40°  | 0°   | 20°  | 40°  | 0°   | 20°  | 40°  | 0°   | 20°  | 40° | 0°   | 20° | 40° | 0°   | 20° |            |
| 12         |      |      |      |      |      |      |      |      |      |      |      |     |      |     |     |      |     | 12         |
| 14         | 32.5 |      |      | 26.7 |      |      | 27.0 |      |      |      |      |     |      |     |     |      |     | 14         |
| 16         | 29.9 |      |      | 24.8 |      |      | 25.7 |      |      | 19.7 |      |     |      |     |     |      |     | 16         |
| 18         | 27.6 | 24.1 |      | 23.3 |      |      | 24.2 |      |      | 18.5 |      |     | 14.2 |     |     | 11.7 |     | 18         |
| 20         | 25.5 | 23   |      | 22   |      |      | 22.8 |      |      | 17.4 |      |     | 13.3 |     |     | 11   |     | 20         |
| 22         | 23.6 | 22   | 16.9 | 20.5 | 15.1 |      | 21.3 | 16.0 |      | 16.5 |      |     | 12.5 |     |     | 10.3 |     | 22         |
| 24         | 21.8 | 21   | 16.3 | 19.1 | 14.4 |      | 19.8 | 15.2 |      | 15.6 |      |     | 11.8 |     |     | 9.7  |     | 24         |
| 26         | 20.2 | 20.1 | 15.9 | 17.8 | 13.7 |      | 18.5 | 14.5 |      | 14.7 | 11.0 |     | 11.2 |     |     | 9.2  |     | 26         |
| 28         | 18.7 | 18.9 | 15.4 | 16.6 | 13.1 | 10.4 | 17.2 | 13.8 | 11.3 | 14.0 | 10.4 |     | 10.6 | 7.7 |     | 8.7  |     | 28         |
| 30         | 17.4 | 17.6 | 15   | 15.4 | 12.5 | 10.1 | 16.0 | 13.2 | 10.8 | 13.3 | 9.9  |     | 10.0 | 7.4 |     | 8.2  |     | 30         |
| 32         | 16.2 | 16.4 | 14.6 | 14.3 | 12   | 9.8  | 14.8 | 12.6 | 10.4 | 12.7 | 9.5  | 7.0 | 9.5  | 7.0 |     | 7.8  | 5.3 | 32         |
| 34         | 15.1 | 15.3 | 14.3 | 13.3 | 11.5 | 9.5  | 13.8 | 12.1 | 10.1 | 12.0 | 9.0  | 6.6 | 9.0  | 6.6 |     | 7.4  | 5   | 34         |
| 36         | 14   | 14.3 | 14   | 12.4 | 11.1 | 9.2  | 12.9 | 11.7 | 9.8  | 11.3 | 8.5  | 6.4 | 8.6  | 6.3 |     | 7    | 4.8 | 36         |
| 38         | 13.1 | 13.3 | 13.4 | 11.6 | 10.7 | 9    | 12.0 | 11.2 | 9.5  | 10.5 | 8.2  | 6.2 | 8.2  | 6.0 | 4.3 | 6.6  | 4.6 | 38         |
| 40         | 12.1 | 12.4 | 12.4 | 10.8 | 10.3 | 8.8  | 11.2 | 10.8 | 9.3  | 9.8  | 7.8  | 6.0 | 7.8  | 5.7 | 4.1 | 6.3  | 4.3 | 40         |
| 42         | 11.2 | 11.5 | 11.5 | 10   | 10   | 8.6  | 10.4 | 10.5 | 9.1  | 9.1  | 7.5  | 5.9 | 7.5  | 5.4 | 4.0 | 6    | 4.1 | 42         |
| 44         | 10.3 | 10.6 | 10.7 | 9.3  | 9.6  | 8.4  | 9.7  | 10.1 | 8.9  | 8.5  | 7.3  | 5.7 | 7.2  | 5.2 | 3.9 | 5.7  | 3.9 | 44         |
| 46         | 9.4  | 9.7  | 9.8  | 8.6  | 9    | 8.2  | 8.9  | 9.4  | 8.6  | 7.9  | 7.0  | 5.5 | 6.8  | 5.0 | 3.8 | 5.5  | 3.7 | 46         |
| 48         | 8.5  | 8.9  | 9.1  | 8    | 8.3  | 8.1  | 8.3  | 8.7  | 8.5  | 7.3  | 6.8  | 5.4 | 6.3  | 4.8 | 3.6 | 5.2  | 3.6 | 48         |
| 50         | 7.5  | 8.1  | 8.3  | 7.3  | 7.7  | 7.9  | 7.6  | 8.0  | 8.3  | 6.8  | 6.5  | 5.3 | 5.8  | 4.6 | 3.5 | 5    | 3.4 | 50         |
| 52         | 6.7  | 7.3  | 7.6  | 6.6  | 7.1  | 7.4  | 6.9  | 7.4  | 7.8  | 6.2  | 6.3  | 5.1 | 5.4  | 4.4 | 3.4 | 4.7  | 3.3 | 52         |
| 54         | 6.1  | 6.6  | 6.9  | 5.9  | 6.4  | 6.8  | 6.1  | 6.7  | 7.1  | 5.7  | 6.1  | 5.0 | 4.9  | 4.2 | 3.4 | 4.4  | 3.2 | 54         |
| 56         | 5.5  | 5.9  |      | 5.2  | 5.8  | 6.2  | 5.4  | 6.1  | 6.5  | 5.2  | 5.9  | 4.9 | 4.4  | 4.1 | 3.3 | 4.0  | 3.0 | 56         |
| 58         | 5.0  | 5.3  |      | 4.6  | 5.4  | 5.7  | 4.8  | 5.6  | 6.0  | 4.6  | 5.4  | 4.8 | 4.0  | 4.0 | 3.2 | 3.7  | 2.9 | 58         |
| 60         | 4.4  | 4.7  |      | 4.1  | 4.9  | 5.3  | 4.3  | 5.1  | 5.5  | 4.1  | 4.9  | 4.8 | 3.6  | 3.8 | 3.1 | 3.3  | 2.8 | 60         |
| 62         | 3.4  | 4.0  |      | 3.6  | 4.4  |      | 3.7  | 4.6  |      | 3.6  | 4.5  | 4.7 | 3.2  | 3.7 | 3.1 | 3.0  | 2.7 | 62         |
| 64         | 2.4  | 2.8  |      | 3.2  | 3.8  |      | 3.3  | 4.0  |      | 3.1  | 4.1  | 4.4 | 2.8  | 3.5 | 3.0 | 2.7  | 2.6 | 64         |
| 66         |      | 1.7  |      | 2.1  | 3.1  |      | 2.7  | 3.4  |      | 2.7  | 3.6  | 4.0 | 2.4  | 3.3 | 3.0 | 2.4  | 2.5 | 66         |
| 68         |      |      |      | 2    |      |      | 1.8  | 2.9  |      | 2.3  | 3.2  | 3.6 | 2.0  | 3.0 | 2.9 | 2.0  | 2.4 | 68         |
| 70         |      |      |      |      |      |      |      | 2.2  |      |      | 2.7  |     |      | 2.6 | 2.9 |      | 2.3 | 70         |
| 72         |      |      |      |      |      |      |      |      |      |      | 2.3  |     |      | 2.3 | 2.7 |      | 2.1 | 72         |
| 74         |      |      |      |      |      |      |      |      |      |      |      |     |      | 1.9 | 2.3 |      | 1.8 | 74         |
| 76         |      |      |      |      |      |      |      |      |      |      |      |     |      |     | 1.9 |      |     | 76         |

# Load Chart - Fixed Jib

Unit: t

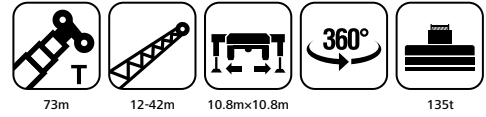

| Radius (m) | 12m  |      |      | 18m  |      |     | 24m  |      |      | 30m  |     |     | 36m  |     |     | 42m |     | Radius (m) |
|------------|------|------|------|------|------|-----|------|------|------|------|-----|-----|------|-----|-----|-----|-----|------------|
|            | 0°   | 20°  | 40°  | 0°   | 20°  | 40° | 0°   | 20°  | 40°  | 0°   | 20° | 40° | 0°   | 20° | 40° | 0°  | 20° |            |
| 12         |      |      |      |      |      |     |      |      |      |      |     |     |      |     |     |     |     | 12         |
| 14         |      |      |      |      |      |     |      |      |      |      |     |     |      |     |     |     |     | 14         |
| 16         | 22.3 |      |      |      |      |     |      |      |      |      |     |     |      |     |     |     |     | 16         |
| 18         | 20.6 |      |      | 17.5 |      |     | 18.2 |      |      | 15.0 |     |     |      |     |     |     |     | 18         |
| 20         | 19.1 | 19.1 |      | 16.3 |      |     | 16.8 |      |      | 14.1 |     |     | 11.9 |     |     |     |     | 20         |
| 22         | 17.8 | 17.8 |      | 15.2 |      |     | 15.7 |      |      | 13.1 |     |     | 11.1 |     |     | 8.7 |     | 22         |
| 24         | 16.5 | 16.7 | 15.9 | 14.3 | 13.5 |     | 14.8 | 14.0 |      | 12.3 |     |     | 10.4 |     |     | 8.3 |     | 24         |
| 26         | 15.4 | 15.6 | 15.4 | 13.3 | 13   |     | 13.7 | 13.7 |      | 11.5 |     |     | 9.7  |     |     | 7.9 |     | 26         |
| 28         | 14.3 | 14.7 | 14.7 | 12.4 | 12.5 |     | 12.8 | 13.1 |      | 10.8 | 9.7 |     | 9.2  |     |     | 7.5 |     | 28         |
| 30         | 13.2 | 13.7 | 13.9 | 11.6 | 11.8 | 9.8 | 12.0 | 12.4 | 10.4 | 10.1 | 9.4 |     | 8.6  |     |     | 7.1 |     | 30         |
| 32         | 12.2 | 12.7 | 13.1 | 10.8 | 11.1 | 9.5 | 11.2 | 11.6 | 10.1 | 9.5  | 8.9 |     | 8.1  | 6.5 |     | 6.7 |     | 32         |
| 34         | 11.3 | 11.8 | 12.2 | 9.9  | 10.5 | 9.3 | 10.2 | 11.0 | 9.9  | 8.8  | 8.6 |     | 7.7  | 6.3 |     | 6.3 |     | 34         |
| 36         | 10.5 | 10.9 | 11.4 | 9.2  | 9.9  | 9.1 | 9.5  | 10.4 | 9.6  | 8.1  | 8.3 | 6.4 | 7.2  | 6.0 |     | 6   | 4.4 | 36         |
| 38         | 9.7  | 10.1 | 10.6 | 8.5  | 9.2  | 8.9 | 8.8  | 9.6  | 9.4  | 7.5  | 8.0 | 6.1 | 6.7  | 5.8 |     | 5.6 | 4.2 | 38         |
| 40         | 8.9  | 9.3  | 9.8  | 7.8  | 8.5  | 8.7 | 8.1  | 8.9  | 9.2  | 6.8  | 7.7 | 5.9 | 6.1  | 5.5 |     | 5.2 | 4   | 40         |
| 42         | 8.3  | 8.6  | 9    | 7.2  | 7.8  | 8.4 | 7.4  | 8.1  | 8.8  | 6.2  | 7.3 | 5.8 | 5.6  | 5.3 | 3.9 | 4.8 | 3.8 | 42         |
| 44         | 7.6  | 8    | 8.3  | 6.6  | 7.2  | 8   | 6.8  | 7.5  | 8.4  | 5.7  | 6.9 | 5.6 | 5.1  | 5.0 | 3.8 | 4.4 | 3.7 | 44         |
| 46         | 7    | 7.3  | 7.7  | 6    | 6.6  | 7.4 | 6.2  | 6.9  | 7.8  | 5.2  | 6.4 | 5.5 | 4.6  | 4.8 | 3.7 | 3.9 | 3.5 | 46         |
| 48         | 6.4  | 6.7  | 7.1  | 5.4  | 6.1  | 6.8 | 5.6  | 6.4  | 7.1  | 4.7  | 5.8 | 5.3 | 4.1  | 4.6 | 3.6 | 3.5 | 3.4 | 48         |
| 50         | 5.8  | 6.2  | 6.4  | 4.9  | 5.6  | 6.3 | 5.1  | 5.8  | 6.6  | 4.3  | 5.3 | 5.2 | 3.7  | 4.5 | 3.5 | 3.2 | 3.3 | 50         |
| 52         | 5.3  | 5.6  | 5.9  | 4.4  | 5.1  | 5.7 | 4.5  | 5.3  | 6.0  | 3.8  | 4.8 | 5.0 | 3.3  | 4.2 | 3.4 | 2.8 | 3.1 | 52         |
| 54         | 4.7  | 5.1  | 5.3  | 4    | 4.6  | 5.2 | 4.1  | 4.8  | 5.4  | 3.4  | 4.4 | 5.0 | 3.0  | 3.8 | 3.3 | 2.5 | 3   | 54         |
| 56         | 4.2  | 4.5  | 4.8  | 3.5  | 4.1  | 4.8 | 3.6  | 4.3  | 5.0  | 3.0  | 4.0 | 4.6 | 2.6  | 3.4 | 3.3 | 2.1 | 2.9 | 56         |
| 58         | 3.7  | 4.0  | 4.3  | 3.1  | 3.7  | 4.3 | 3.2  | 3.8  | 4.5  | 2.6  | 3.6 | 4.1 | 2.3  | 3.1 | 3.2 |     | 2.7 | 58         |
| 60         | 3.2  | 3.6  | 3.8  | 2.7  | 3.3  | 3.8 | 2.8  | 3.4  | 4.0  | 2.1  | 3.2 | 3.7 |      | 2.7 | 3.1 |     | 2.4 | 60         |
| 62         | 2.8  | 3.2  |      | 2.3  | 2.9  | 3.4 | 2.4  | 3.0  | 3.5  |      | 2.8 | 3.3 |      | 2.4 | 3.0 |     | 2.1 | 62         |
| 64         | 2.3  | 2.7  |      | 2.0  | 2.5  | 3.0 | 2.1  | 2.6  | 3.1  |      | 2.4 | 2.9 |      | 2.0 | 2.7 |     | 1.8 | 64         |
| 66         | 1.9  | 2.2  |      |      | 2.1  | 2.6 |      | 2.2  | 2.7  |      | 2.0 | 2.5 |      |     | 2.3 |     |     | 66         |
| 68         |      | 1.8  |      |      |      | 2.2 |      |      | 2.3  |      |     |     |      |     | 2.0 |     |     | 68         |
| 70         |      |      |      |      |      |     |      |      |      |      |     | 1.7 |      |     |     |     |     | 70         |

# Load Chart - Fixed Jib

Unit: t

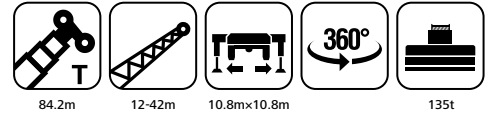

| Radius (m) | 12m  |      |      | 18m  |     |     | 24m  |     |     | 30m |     |     | 36m |     |     | 42m |     | Radius (m) |
|------------|------|------|------|------|-----|-----|------|-----|-----|-----|-----|-----|-----|-----|-----|-----|-----|------------|
|            | 0°   | 20°  | 40°  | 0°   | 20° | 40° | 0°   | 20° | 40° | 0°  | 20° | 40° | 0°  | 20° | 40° | 0°  | 20° |            |
| 12         |      |      |      |      |     |     |      |     |     |     |     |     |     |     |     |     |     | 12         |
| 14         |      |      |      |      |     |     |      |     |     |     |     |     |     |     |     |     |     | 14         |
| 16         |      |      |      |      |     |     |      |     |     |     |     |     |     |     |     |     |     | 16         |
| 18         | 14.8 |      |      |      |     |     |      |     |     |     |     |     |     |     |     |     |     | 18         |
| 20         | 13.7 |      |      | 11.5 |     |     | 12.0 |     |     |     |     |     |     |     |     |     |     | 20         |
| 22         | 12.8 |      |      | 10.7 |     |     | 11.0 |     |     | 9.3 |     |     |     |     |     |     |     | 22         |
| 24         | 11.9 | 12.3 |      | 10   |     |     | 10.3 |     |     | 8.5 |     |     | 7.0 |     |     |     |     | 24         |
| 26         | 11.2 | 11.5 |      | 9.3  |     |     | 9.6  |     |     | 7.8 |     |     | 6.5 |     |     | 5.2 |     | 26         |
| 28         | 10.5 | 10.7 | 11.1 | 8.7  | 9.3 |     | 9.0  | 9.9 |     | 7.3 |     |     | 6.0 |     |     | 4.8 |     | 28         |
| 30         | 9.9  | 10   | 10.4 | 8.2  | 8.7 |     | 8.4  | 9.1 |     | 6.8 |     |     | 5.6 |     |     | 4.4 |     | 30         |
| 32         | 9.2  | 9.4  | 9.7  | 7.7  | 8.1 |     | 7.9  | 8.5 |     | 6.4 | 7.2 |     | 5.1 |     |     | 4.1 |     | 32         |
| 34         | 8.6  | 8.8  | 9.1  | 7.2  | 7.6 | 8.1 | 7.4  | 7.9 | 8.9 | 6.0 | 6.7 |     | 4.7 |     |     | 3.8 |     | 34         |
| 36         | 7.8  | 8.3  | 8.6  | 6.8  | 7.1 | 7.6 | 7.0  | 7.4 | 8.0 | 5.6 | 6.2 |     | 4.4 | 5.1 |     | 3.5 |     | 36         |
| 38         | 7.2  | 7.7  | 8    | 6.3  | 6.6 | 7.1 | 6.5  | 6.9 | 7.5 | 5.2 | 5.7 |     | 4.1 | 4.7 |     | 3.2 |     | 38         |
| 40         | 6.6  | 7.1  | 7.5  | 5.7  | 6.2 | 6.6 | 5.9  | 6.5 | 6.9 | 4.8 | 5.3 | 5.7 | 3.7 | 4.4 |     | 2.9 | 3.5 | 40         |
| 42         | 6    | 6.5  | 7    | 5.2  | 5.8 | 6.2 | 5.4  | 6.0 | 6.5 | 4.4 | 4.9 | 5.5 | 3.4 | 4.0 |     | 2.6 | 3.3 | 42         |
| 44         | 5.4  | 5.9  | 6.6  | 4.7  | 5.4 | 5.8 | 4.8  | 5.6 | 6.1 | 4.0 | 4.6 | 5.1 | 3.1 | 3.7 |     |     | 3.1 | 44         |
| 46         | 4.9  | 5.4  | 6    | 4.3  | 5   | 5.4 | 4.4  | 5.2 | 5.7 | 3.6 | 4.2 | 4.7 | 2.8 | 3.4 | 3.5 |     | 2.8 | 46         |
| 48         | 4.4  | 4.9  | 5.5  | 3.9  | 4.6 | 5   | 4.0  | 4.8 | 5.2 | 3.2 | 3.9 | 4.4 | 2.5 | 3.1 | 3.5 |     | 2.5 | 48         |
| 50         | 4    | 4.4  | 5    | 3.4  | 4.1 | 4.6 | 3.5  | 4.3 | 4.8 | 2.8 | 3.6 | 4.0 |     | 2.8 | 3.3 |     | 2.3 | 50         |
| 52         | 3.5  | 4    | 4.5  | 3    | 3.7 | 4.2 | 3.1  | 3.8 | 4.4 | 2.3 | 3.2 | 3.7 |     | 2.6 | 3.1 |     |     | 52         |
| 54         | 3.1  | 3.5  | 4    | 2.7  | 3.3 | 3.8 | 2.8  | 3.4 | 4.0 |     | 2.9 | 3.4 |     | 2.3 | 2.8 |     |     | 54         |
| 56         | 2.7  | 3.1  | 3.6  | 2.3  | 2.9 | 3.4 | 2.4  | 3.0 | 3.5 |     | 2.6 | 3.1 |     | 2.0 | 2.5 |     |     | 56         |
| 58         | 2.3  | 2.7  | 3.2  |      | 2.5 | 3.0 |      | 2.6 | 3.1 |     | 2.1 | 2.8 |     |     | 2.3 |     |     | 58         |
| 60         |      | 2.3  | 2.8  |      | 2.2 | 2.6 |      | 2.3 | 2.7 |     |     | 2.5 |     |     | 2.0 |     |     | 60         |
| 62         |      | 1.9  | 2.4  |      |     | 2.2 |      |     | 2.3 |     |     | 2.0 |     |     |     |     |     | 62         |
| 64         |      |      | 2.0  |      |     | 1.9 |      |     | 2.0 |     |     |     |     |     |     |     |     | 64         |

# Load Chart - Fixed Jib

Unit: t

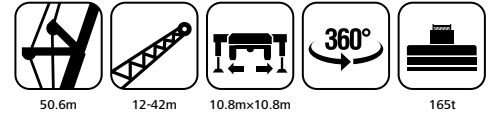

| Radius (m) | 12m  |      |      | 18m  |      |      | 24m  |      |      | 30m  |      |     | 36m  |      |     | 42m  |      |     | Radius (m) |
|------------|------|------|------|------|------|------|------|------|------|------|------|-----|------|------|-----|------|------|-----|------------|
|            | 0°   | 20°  | 40°  | 0°   | 20°  | 40°  | 0°   | 20°  | 40°  | 0°   | 20°  | 40° | 0°   | 20°  | 40° | 0°   | 20°  | 40° |            |
| 12         | 74   |      |      | 53   |      |      | 55.3 |      |      |      |      |     |      |      |     |      |      |     | 12         |
| 14         | 69   |      |      | 49.5 |      |      | 51.7 |      |      | 39.0 |      |     |      |      |     |      |      |     | 14         |
| 16         | 64   | 41   |      | 46.5 |      |      | 48.5 |      |      | 36.4 |      |     | 28.9 |      |     | 23.7 |      |     | 16         |
| 18         | 61   | 40   |      | 43.5 |      |      | 45.4 |      |      | 33.9 |      |     | 27.0 |      |     | 22.2 |      |     | 18         |
| 20         | 57   | 38.5 | 25.7 | 41   | 24.7 |      | 42.8 | 26.3 |      | 31.8 |      |     | 25.5 |      |     | 20.9 |      |     | 20         |
| 22         | 53   | 37   | 25.4 | 39   | 24.6 |      | 40.7 | 26.2 |      | 30.3 |      |     | 24.0 |      |     | 19.7 |      |     | 22         |
| 24         | 48   | 36   | 24.9 | 37   | 24.3 | 15   | 38.6 | 25.8 | 16.2 | 28.6 | 16.9 |     | 22.8 |      |     | 18.6 |      |     | 24         |
| 26         | 44.5 | 34.5 | 24.4 | 35   | 23.9 | 15.2 | 36.5 | 25.3 | 16.3 | 27.1 | 16.5 |     | 21.6 | 12.6 |     | 17.7 |      |     | 26         |
| 28         | 40.5 | 33.5 | 23.9 | 33.5 | 23.4 | 15.4 | 35.0 | 24.8 | 16.3 | 26.0 | 16.3 |     | 20.4 | 12.6 |     | 16.8 |      |     | 28         |
| 30         | 37   | 32.5 | 23.5 | 32   | 22.8 | 15.4 | 33.4 | 24.1 | 16.3 | 24.7 | 16.1 | 9.3 | 19.5 | 12.6 |     | 15.9 | 10.6 |     | 30         |
| 32         | 33.5 | 31.5 | 23.2 | 30.5 | 22.1 | 15.2 | 31.8 | 23.3 | 16.2 | 23.5 | 15.9 | 9.4 | 18.6 | 12.6 |     | 15.2 | 10.3 |     | 32         |
| 34         | 30.5 | 31   | 22.8 | 29.1 | 21.4 | 15   | 30.4 | 22.6 | 16.0 | 22.4 | 15.7 | 9.5 | 17.8 | 12.6 |     | 14.5 | 10   |     | 34         |
| 36         | 27.3 | 29.5 | 22.6 | 27.8 | 20.7 | 14.7 | 29.0 | 21.8 | 15.6 | 21.5 | 15.5 | 9.6 | 16.9 | 12.6 | 7.1 | 13.9 | 9.7  |     | 36         |
| 38         | 24.5 | 26.5 | 22.3 | 25.8 | 20.1 | 14.4 | 26.9 | 21.2 | 15.3 | 20.6 | 15.3 | 9.7 | 16.2 | 12.5 | 7.1 | 13.2 | 9.5  |     | 38         |
| 40         | 22   | 23.9 | 22.1 | 23.5 | 19.6 | 14.1 | 24.5 | 20.6 | 14.9 | 19.7 | 15.1 | 9.7 | 15.6 | 12.2 | 7.2 | 12.5 | 9.3  |     | 40         |
| 42         | 19.7 | 21.5 | 22   | 21.3 | 19   | 13.9 | 22.2 | 20.0 | 14.7 | 18.8 | 14.8 | 9.7 | 14.9 | 11.8 | 7.1 | 12.1 | 9.1  |     | 42         |
| 44         | 17.7 | 19.3 | 20.3 | 19.2 | 18.5 | 13.7 | 20.0 | 19.5 | 14.5 | 18.1 | 14.4 | 9.6 | 14.3 | 11.4 | 7.1 | 11.6 | 8.8  |     | 44         |
| 46         | 15.8 | 17.2 | 18.1 | 17.3 | 18.1 | 13.5 | 18.1 | 19.0 | 14.3 | 17.5 | 14.0 | 9.5 | 13.7 | 11.1 | 7.0 | 11.1 | 8.5  |     | 46         |
| 48         | 14.1 | 15.4 |      | 15.6 | 17.6 | 13.4 | 16.3 | 18.5 | 14.1 | 16.7 | 13.6 | 9.3 | 13.2 | 10.7 | 6.8 | 10.7 | 8.1  |     | 48         |
| 50         | 12.5 | 13.7 |      | 14.1 | 16   | 13.3 | 14.7 | 16.8 | 14.0 | 15.6 | 13.2 | 9.2 | 12.7 | 10.4 | 6.6 | 10.2 | 7.8  |     | 50         |
| 52         | 11.1 | 12.1 |      | 12.6 | 14.3 | 13.2 | 13.2 | 15.0 | 13.9 | 14.1 | 12.9 | 9.0 | 12.2 | 10.1 | 6.5 | 9.8  | 7.5  |     | 52         |
| 54         | 9.8  | 10.6 |      | 11.3 | 12.8 | 13.2 | 11.8 | 13.4 | 13.9 | 12.7 | 12.6 | 8.9 | 11.5 | 9.7  | 6.4 | 9.4  | 7.3  |     | 54         |
| 56         | 8.5  | 9.2  |      | 10   | 11.4 |      | 10.4 | 11.9 |      | 11.4 | 12.2 | 8.9 | 11.0 | 9.5  | 6.2 | 9    | 7    |     | 56         |
| 58         | 6.4  |      |      | 8.9  | 10.1 |      | 9.3  | 10.6 |      | 10.2 | 11.9 | 8.8 | 10.6 | 9.2  | 6.1 | 8.6  | 6.8  |     | 58         |
| 60         |      |      |      | 7.8  | 8.9  |      | 8.1  | 9.3  |      | 9.1  | 10.9 | 8.8 | 10.0 | 9.0  | 6.0 | 8.1  | 6.5  |     | 60         |
| 62         |      |      |      | 6.8  | 7.7  |      | 7.1  | 8.1  |      | 8.1  | 9.8  |     | 9.0  | 8.7  | 6.0 | 7.7  | 6.3  |     | 62         |
| 64         |      |      |      | 5.1  | 6.6  |      | 5.3  | 6.9  |      | 7.1  | 8.5  |     | 8.0  | 8.5  | 5.9 | 7.5  | 6.1  |     | 64         |
| 66         |      |      |      |      |      |      | 3.3  |      |      | 6.2  | 7.5  |     | 7.1  | 8.4  | 5.8 | 7.2  | 6    |     | 66         |
| 68         |      |      |      |      |      |      |      |      |      | 5.2  | 6.5  |     | 6.0  | 8.0  | 5.8 | 6.9  | 5.8  |     | 68         |
| 70         |      |      |      |      |      |      |      |      |      | 4.1  | 5.4  |     | 4.8  | 7.0  |     | 5.7  | 5.6  |     | 70         |
| 72         |      |      |      |      |      |      |      |      |      | 2.7  |      |     | 3.8  | 6.0  |     | 4.65 | 5.5  |     | 72         |
| 74         |      |      |      |      |      |      |      |      |      |      |      |     | 2.7  | 4.8  |     | 3.6  | 5.3  |     | 74         |
| 76         |      |      |      |      |      |      |      |      |      |      |      |     | 1.8  | 3.6  |     | 2.7  | 5.2  |     | 76         |
| 78         |      |      |      |      |      |      |      |      |      |      |      |     |      | 2.4  |     | 2    | 4.1  |     | 78         |
| 80         |      |      |      |      |      |      |      |      |      |      |      |     |      |      |     |      | 3.0  |     | 80         |
| 82         |      |      |      |      |      |      |      |      |      |      |      |     |      |      |     |      | 2.0  |     | 82         |

# Load Chart - Fixed Jib

Unit: t

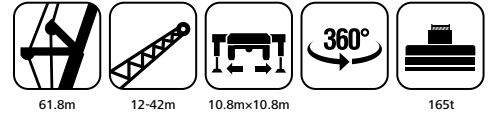

| Radius (m) | 12m  |      |      | 18m  |      |      | 24m  |      |      | 30m  |      |     | 36m  |      |     | 42m  |      |     | Radius (m) |
|------------|------|------|------|------|------|------|------|------|------|------|------|-----|------|------|-----|------|------|-----|------------|
|            | 0°   | 20°  | 40°  | 0°   | 20°  | 40°  | 0°   | 20°  | 40°  | 0°   | 20°  | 40° | 0°   | 20°  | 40° | 0°   | 20°  | 40° |            |
| 12         |      |      |      |      |      |      |      |      |      |      |      |     |      |      |     |      |      |     | 12         |
| 14         | 67   |      |      |      |      |      |      |      |      |      |      |     |      |      |     |      |      |     | 14         |
| 16         | 64   |      |      | 46.5 |      |      | 48.3 |      |      | 36.3 |      |     |      |      |     |      |      |     | 16         |
| 18         | 59   | 40.5 |      | 44   |      |      | 45.7 |      |      | 34.3 |      |     | 26.3 |      |     | 21.5 |      |     | 18         |
| 20         | 54   | 39   |      | 42   |      |      | 43.6 |      |      | 32.8 |      |     | 25.0 |      |     | 20.4 |      |     | 20         |
| 22         | 48.5 | 37.5 | 25.1 | 39.5 | 24.7 |      | 41.0 | 26.2 |      | 30.7 |      |     | 23.8 |      |     | 19.3 |      |     | 22         |
| 24         | 44.5 | 36.5 | 25.1 | 38   | 24.7 |      | 39.4 | 26.1 |      | 29.4 |      |     | 22.6 |      |     | 18.4 |      |     | 24         |
| 26         | 41   | 35.5 | 24.6 | 36.5 | 24.7 |      | 37.9 | 26.1 |      | 28.1 | 17.1 |     | 21.4 |      |     | 17.6 |      |     | 26         |
| 28         | 38   | 34.5 | 24.2 | 34.5 | 24.7 | 14.7 | 35.8 | 26.0 | 15.7 | 26.9 | 17.0 |     | 20.6 |      |     | 16.7 |      |     | 28         |
| 30         | 35   | 33.5 | 23.8 | 33   | 24.1 | 15   | 34.3 | 25.4 | 16.0 | 25.6 | 17.0 |     | 19.7 | 12.6 |     | 16   |      |     | 30         |
| 32         | 32.5 | 32.5 | 23.4 | 31.5 | 23.4 | 15.3 | 32.7 | 24.6 | 16.0 | 24.7 | 16.9 | 9.3 | 18.8 | 12.6 |     | 15.3 |      |     | 32         |
| 34         | 29.8 | 31.5 | 23.1 | 29.3 | 22.7 | 15.2 | 30.4 | 23.9 | 16.0 | 23.7 | 16.7 | 9.5 | 18.0 | 12.6 |     | 14.6 | 10.1 |     | 34         |
| 36         | 27.1 | 29   | 22.9 | 27.2 | 22.1 | 14.9 | 28.2 | 23.2 | 15.8 | 22.8 | 16.5 | 9.7 | 17.4 | 12.6 |     | 14   | 10   |     | 36         |
| 38         | 24.6 | 26.8 | 22.6 | 25   | 21.5 | 14.6 | 25.9 | 22.6 | 15.5 | 21.9 | 16.3 | 9.9 | 16.7 | 12.6 | 6.7 | 13.5 | 9.8  |     | 38         |
| 40         | 22.4 | 24.4 | 22.3 | 22.8 | 20.9 | 14.4 | 23.7 | 21.9 | 15.2 | 21.1 | 15.8 | 9.9 | 16.1 | 12.5 | 6.8 | 13   | 9.7  |     | 40         |
| 42         | 20.4 | 22.2 | 22.2 | 20.9 | 20.3 | 14.2 | 21.7 | 21.3 | 15.0 | 20.4 | 15.4 | 9.9 | 15.4 | 12.2 | 7.0 | 12.5 | 9.4  |     | 42         |
| 44         | 18.5 | 20.2 | 21.4 | 19.1 | 19.9 | 14   | 19.8 | 20.8 | 14.8 | 19.7 | 15.0 | 9.8 | 14.9 | 11.9 | 7.1 | 12   | 9.1  |     | 44         |
| 46         | 16.7 | 18.2 | 19.3 | 17.4 | 19.4 | 13.8 | 18.1 | 20.3 | 14.5 | 18.2 | 14.6 | 9.7 | 14.4 | 11.6 | 7.0 | 11.5 | 8.8  |     | 46         |
| 48         | 15   | 16.4 | 17.4 | 15.9 | 18.1 | 13.6 | 16.5 | 18.9 | 14.3 | 16.7 | 14.2 | 9.5 | 14.0 | 11.3 | 6.9 | 11.1 | 8.5  |     | 48         |
| 50         | 13.4 | 14.7 | 15.6 | 14.4 | 16.5 | 13.5 | 14.9 | 17.2 | 14.2 | 15.3 | 13.9 | 9.4 | 13.5 | 10.9 | 6.8 | 10.7 | 8.2  |     | 50         |
| 52         | 12   | 13.2 | 13.9 | 13   | 14.9 | 13.3 | 13.5 | 15.6 | 14.0 | 13.9 | 13.5 | 9.2 | 12.9 | 10.6 | 6.7 | 10.4 | 8    |     | 52         |
| 54         | 10.6 | 11.7 | 12.4 | 11.7 | 13.4 | 13.3 | 12.1 | 14.0 | 14.0 | 12.7 | 13.1 | 9.1 | 12.4 | 10.3 | 6.5 | 10   | 7.7  |     | 54         |
| 56         | 9.4  | 10.4 |      | 10.4 | 12.1 | 13.2 | 10.8 | 12.6 | 13.8 | 11.5 | 12.8 | 8.9 | 11.9 | 10.1 | 6.4 | 9.6  | 7.4  |     | 56         |
| 58         | 8.2  | 9.2  |      | 9.3  | 10.8 | 11.8 | 9.7  | 11.3 | 12.4 | 10.3 | 12.4 | 8.8 | 10.9 | 9.8  | 6.3 | 9.3  | 7.2  |     | 58         |
| 60         | 7.2  | 8    |      | 8.2  | 9.6  | 10.5 | 8.5  | 10.0 | 11.0 | 9.2  | 11.3 | 8.7 | 9.9  | 9.5  | 6.2 | 8.9  | 7    |     | 60         |
| 62         | 6.2  | 6.9  |      | 7.2  | 8.5  |      | 7.5  | 8.9  |      | 8.2  | 10.2 | 8.6 | 8.9  | 9.3  | 6.1 | 8.5  | 6.8  |     | 62         |
| 64         | 5.2  | 5.9  |      | 6.2  | 7.4  |      | 6.4  | 7.7  |      | 7.3  | 9.0  | 8.6 | 8.0  | 9.1  | 6.0 | 8.2  | 6.6  |     | 64         |
| 66         | 4.2  | 4.9  |      | 5.4  | 6.4  |      | 5.6  | 6.7  |      | 6.3  | 8.0  | 8.5 | 7.1  | 8.9  | 5.9 | 7.4  | 6.3  |     | 66         |
| 68         | 2.7  |      |      | 4.6  | 5.5  |      | 4.8  | 5.7  |      | 5.4  | 7.0  | 8.0 | 6.3  | 8.3  | 5.9 | 6.6  | 6.2  |     | 68         |
| 70         |      |      |      | 4    | 4.5  |      | 4.2  | 4.9  |      | 4.7  | 6.0  |     | 5.3  | 7.3  | 5.8 | 5.8  | 6    |     | 70         |
| 72         |      |      |      | 2.6  | 3    |      | 3.1  | 4.2  |      | 4.2  | 5.1  |     | 4.2  | 6.5  | 5.8 | 4.8  | 5.9  |     | 72         |
| 74         |      |      |      | 1.5  |      |      | 2.0  |      |      | 3.2  | 4.5  |     | 3.2  | 5.6  | 5.7 | 3.8  | 5.7  |     | 74         |
| 76         |      |      |      |      |      |      |      |      |      | 2.1  | 3.9  |     | 2.3  | 4.5  |     | 2.9  | 5.6  |     | 76         |
| 78         |      |      |      |      |      |      |      |      |      |      | 2.9  |     |      | 3.5  |     | 2.0  | 4.8  |     | 78         |
| 80         |      |      |      |      |      |      |      |      |      |      | 1.8  |     |      | 2.4  |     |      | 3.75 |     | 80         |
| 82         |      |      |      |      |      |      |      |      |      |      |      |     |      | 1.5  |     |      | 3    |     | 82         |

# Load Chart - Fixed Jib

Unit: t

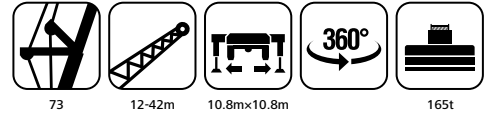

| Radius (m) | 12m  |      |      | 18m  |      |      | 24m  |      |      | 30m  |      |     | 36m  |      |     | 42m  |     |     | Radius (m) |
|------------|------|------|------|------|------|------|------|------|------|------|------|-----|------|------|-----|------|-----|-----|------------|
|            | 0°   | 20°  | 40°  | 0°   | 20°  | 40°  | 0°   | 20°  | 40°  | 0°   | 20°  | 40° | 0°   | 20°  | 40° | 0°   | 20° | 40° |            |
| 12         |      |      |      |      |      |      |      |      |      |      |      |     |      |      |     |      |     |     | 12         |
| 14         |      |      |      |      |      |      |      |      |      |      |      |     |      |      |     |      |     |     | 14         |
| 16         |      |      |      |      |      |      |      |      |      |      |      |     |      |      |     |      |     |     | 16         |
| 18         | 48.5 |      |      |      |      |      |      |      |      |      |      |     |      |      |     |      |     |     | 18         |
| 20         | 46   |      |      | 38.5 |      |      | 39.8 |      |      | 29.9 |      |     |      |      |     |      |     |     | 20         |
| 22         | 43.5 |      |      | 37   |      |      | 38.2 |      |      | 28.7 |      |     | 22.8 |      |     |      |     |     | 22         |
| 24         | 40.5 | 36.5 |      | 35   |      |      | 36.2 |      |      | 27.6 |      |     | 21.9 |      |     | 17.2 |     |     | 24         |
| 26         | 38.5 | 35.5 | 24.4 | 33.5 | 24.7 |      | 34.6 | 26.0 |      | 26.5 |      |     | 21.0 |      |     | 16.4 |     |     | 26         |
| 28         | 35.5 | 34.5 | 24   | 31.5 | 24.4 |      | 32.6 | 25.7 |      | 25.4 |      |     | 20.2 |      |     | 15.8 |     |     | 28         |
| 30         | 33   | 33   | 23.7 | 30   | 23.7 | 14.5 | 31.0 | 24.9 | 15.4 | 24.5 | 16.8 |     | 19.4 |      |     | 15.2 |     |     | 30         |
| 32         | 30.5 | 31.5 | 23.3 | 28.4 | 23.1 | 15.1 | 29.4 | 24.2 | 16.0 | 23.7 | 16.9 |     | 18.7 |      |     | 14.6 |     |     | 32         |
| 34         | 28.2 | 29.4 | 23.1 | 26.9 | 22.5 | 15.1 | 27.8 | 23.6 | 16.0 | 22.9 | 16.6 |     | 18.1 | 12.6 |     | 14   |     |     | 34         |
| 36         | 26.2 | 27.4 | 22.8 | 25.5 | 21.9 | 14.9 | 26.4 | 22.9 | 15.8 | 22.1 | 16.4 | 9.2 | 17.4 | 12.6 |     | 13.5 |     |     | 36         |
| 38         | 24.3 | 25.5 | 22.6 | 23.7 | 21.4 | 14.6 | 24.5 | 22.4 | 15.4 | 21.2 | 16.1 | 9.5 | 16.8 | 12.6 |     | 13.1 | 9.7 |     | 38         |
| 40         | 22.3 | 23.8 | 22.4 | 22.2 | 20.9 | 14.4 | 22.9 | 21.8 | 15.2 | 20.4 | 15.7 | 9.7 | 16.3 | 12.5 |     | 12.6 | 9.6 |     | 40         |
| 42         | 20.4 | 22.2 | 22.2 | 20.5 | 20.4 | 14.2 | 21.2 | 21.3 | 15.0 | 19.6 | 15.3 | 9.9 | 15.8 | 12.2 | 6.6 | 12.1 | 9.3 |     | 42         |
| 44         | 18.6 | 20.3 | 21.6 | 18.8 | 20   | 14.1 | 19.4 | 20.9 | 14.8 | 18.8 | 14.9 | 9.9 | 15.3 | 11.9 | 6.8 | 11.8 | 9.1 |     | 44         |
| 46         | 17   | 18.6 | 19.8 | 17.3 | 19.4 | 13.9 | 17.9 | 20.2 | 14.6 | 17.8 | 14.6 | 9.7 | 14.8 | 11.6 | 6.9 | 11.4 | 8.8 |     | 46         |
| 48         | 15.4 | 16.9 | 18.1 | 15.8 | 18   | 13.7 | 16.3 | 18.8 | 14.4 | 16.3 | 14.3 | 9.5 | 14.3 | 11.3 | 6.9 | 11   | 8.5 |     | 48         |
| 50         | 14   | 15.4 | 16.5 | 14.4 | 16.5 | 13.6 | 14.9 | 17.2 | 14.3 | 15.0 | 13.9 | 9.4 | 13.8 | 11.0 | 6.8 | 10.7 | 8.3 |     | 50         |
| 52         | 12.7 | 14   | 15   | 13.2 | 15.1 | 13.5 | 13.6 | 15.7 | 14.1 | 13.7 | 13.6 | 9.3 | 13.2 | 10.8 | 6.7 | 10.3 | 8.1 |     | 52         |
| 54         | 11.4 | 12.7 | 13.5 | 12   | 13.8 | 13.4 | 12.4 | 14.4 | 14.0 | 12.6 | 13.3 | 9.1 | 12.5 | 10.5 | 6.6 | 9.9  | 7.8 |     | 54         |
| 56         | 10   | 11.4 | 12.1 | 10.9 | 12.6 | 13.2 | 11.3 | 13.1 | 13.8 | 11.4 | 12.9 | 8.9 | 11.5 | 10.3 | 6.5 | 9.5  | 7.6 |     | 56         |
| 58         | 8.6  | 10.2 | 10.8 | 9.8  | 11.5 | 12.7 | 10.1 | 12.0 | 13.3 | 10.4 | 12.6 | 8.8 | 10.5 | 10.0 | 6.4 | 9    | 7.4 |     | 58         |
| 60         | 7.5  | 9    | 9.6  | 8.6  | 10.4 | 11.4 | 8.9  | 10.8 | 11.9 | 9.4  | 11.6 | 8.7 | 9.6  | 9.8  | 6.3 | 8.6  | 7.2 |     | 60         |
| 62         | 6.4  | 7.9  |      | 7.4  | 9.3  | 10.2 | 7.6  | 9.7  | 10.6 | 8.5  | 10.5 | 8.7 | 8.7  | 9.6  | 6.2 | 8.2  | 7   |     | 62         |
| 64         | 5.4  | 6.7  |      | 6.3  | 8.2  | 9.1  | 6.5  | 8.5  | 9.5  | 7.7  | 9.6  | 8.6 | 7.8  | 9.4  | 6.1 | 7.8  | 6.8 |     | 64         |
| 66         | 4.3  | 5.6  |      | 5.3  | 7.2  | 8    | 5.5  | 7.5  | 8.3  | 6.7  | 8.6  | 8.4 | 7.1  | 9.2  | 6.0 | 7    | 6.6 |     | 66         |
| 68         | 3.2  | 4.5  |      | 4.4  | 6.3  | 7    | 4.5  | 6.5  | 7.3  | 5.8  | 7.7  | 8.0 | 6.3  | 8.4  | 5.9 | 6.3  | 6.4 |     | 68         |
| 70         | 2.5  | 3.4  |      | 3.5  | 5.5  |      | 3.6  | 5.7  |      | 4.9  | 6.8  | 7.5 | 5.7  | 7.6  | 5.9 | 5.6  | 6.3 |     | 70         |
| 72         | 1.8  | 2.5  |      | 2.6  | 4.4  |      | 2.7  | 4.6  |      | 4.1  | 5.8  | 6.9 | 4.7  | 6.8  | 5.8 | 4.9  | 6.1 |     | 72         |
| 74         |      | 1.6  |      | 1.6  | 3.4  |      | 1.7  | 3.5  |      | 3.3  | 5.0  | 5.9 | 3.6  | 6.0  | 5.7 | 4.1  | 5.9 |     | 74         |
| 76         |      |      |      |      | 2.4  |      |      | 2.5  |      | 2.5  | 4.4  |     | 2.7  | 5.2  | 5.7 | 3.2  | 5.7 |     | 76         |
| 78         |      |      |      |      | 1.7  |      |      | 1.8  |      |      | 3.6  |     | 1.8  | 4.4  | 5.6 | 2.3  | 5   |     | 78         |
| 80         |      |      |      |      |      |      |      |      |      |      | 2.7  |     |      | 3.3  | 4.7 |      | 4.4 |     | 80         |
| 82         |      |      |      |      |      |      |      |      |      |      |      |     |      | 2.4  | 4.1 |      | 3.3 |     | 82         |

# Load Chart - Fixed Jib

Unit: t

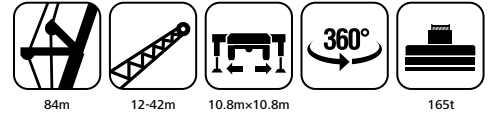

| Radius (m) | 12m  |      |      | 18m  |      |      | 24m  |      |      | 30m  |      |     | 36m  |     |     | 42m  |     |     | Radius (m) |
|------------|------|------|------|------|------|------|------|------|------|------|------|-----|------|-----|-----|------|-----|-----|------------|
|            | 0°   | 20°  | 40°  | 0°   | 20°  | 40°  | 0°   | 20°  | 40°  | 0°   | 20°  | 40° | 0°   | 20° | 40° | 0°   | 20° | 40° |            |
| 12         |      |      |      |      |      |      |      |      |      |      |      |     |      |     |     |      |     |     | 12         |
| 14         |      |      |      |      |      |      |      |      |      |      |      |     |      |     |     |      |     |     | 14         |
| 16         |      |      |      |      |      |      |      |      |      |      |      |     |      |     |     |      |     |     | 16         |
| 18         |      |      |      |      |      |      |      |      |      |      |      |     |      |     |     |      |     |     | 18         |
| 20         |      |      |      |      |      |      |      |      |      |      |      |     |      |     |     |      |     |     | 20         |
| 22         | 27.7 |      |      |      |      |      |      |      |      |      |      |     |      |     |     |      |     |     | 22         |
| 24         | 26.4 |      |      | 22   |      |      | 22.7 |      |      |      |      |     |      |     |     |      |     |     | 24         |
| 26         | 25.3 | 22.8 |      | 21   |      |      | 21.6 |      |      | 17.3 |      |     |      |     |     |      |     |     | 26         |
| 28         | 24.1 | 21.9 |      | 20.1 |      |      | 20.7 |      |      | 16.6 |      |     | 13.9 |     |     | 12.5 |     |     | 28         |
| 30         | 23.1 | 21.1 | 19.2 | 19.3 | 16.9 |      | 19.9 | 17.7 |      | 15.9 |      |     | 13.3 |     |     | 12.3 |     |     | 30         |
| 32         | 22.2 | 20.3 | 19   | 18.5 | 16.5 |      | 19.1 | 17.3 |      | 15.3 |      |     | 12.8 |     |     | 11.8 |     |     | 32         |
| 34         | 21.3 | 19.5 | 18.5 | 17.7 | 16   | 11.7 | 18.2 | 16.7 | 12.4 | 14.6 | 10.8 |     | 12.2 |     |     | 11.3 |     |     | 34         |
| 36         | 20.3 | 18.9 | 18   | 17   | 15.4 | 11.7 | 17.5 | 16.1 | 12.3 | 14.0 | 10.7 |     | 11.7 |     |     | 10.9 |     |     | 36         |
| 38         | 19.3 | 18.2 | 17.5 | 16.3 | 14.8 | 11.7 | 16.8 | 15.4 | 12.3 | 13.5 | 10.5 |     | 11.2 | 8.2 |     | 10.4 |     |     | 38         |
| 40         | 18.3 | 17.5 | 16.9 | 15.7 | 14.4 | 11.8 | 16.2 | 15.0 | 12.3 | 12.9 | 10.4 | 7.0 | 10.8 | 8.0 |     | 10   |     |     | 40         |
| 42         | 17.3 | 17   | 16.4 | 15.1 | 13.9 | 11.8 | 15.6 | 14.5 | 12.3 | 12.3 | 10.1 | 7.0 | 10.4 | 7.9 |     | 9.6  | 6.7 |     | 42         |
| 44         | 16.2 | 16.4 | 15.9 | 14.6 | 13.4 | 11.8 | 15.0 | 14.0 | 12.3 | 11.9 | 10.0 | 7.0 | 9.9  | 7.7 |     | 9.3  | 6.5 |     | 44         |
| 46         | 15.2 | 15.9 | 15.4 | 14   | 12.9 | 11.8 | 14.4 | 13.4 | 12.3 | 11.5 | 9.8  | 7.0 | 9.5  | 7.6 | 4.7 | 8.9  | 6.4 |     | 46         |
| 48         | 14.2 | 15.3 | 14.9 | 13.4 | 12.5 | 11.8 | 13.8 | 13.0 | 12.3 | 11.0 | 9.7  | 7.0 | 9.2  | 7.5 | 4.7 | 8.5  | 6.3 |     | 48         |
| 50         | 13.2 | 14.6 | 14.5 | 12.8 | 12.1 | 11.6 | 13.2 | 12.6 | 12.1 | 10.6 | 9.6  | 7.0 | 8.8  | 7.4 | 4.7 | 8.2  | 6.1 |     | 50         |
| 52         | 12.2 | 13.6 | 13.8 | 12   | 11.8 | 11.2 | 12.4 | 12.3 | 11.7 | 10.2 | 9.3  | 7.1 | 8.5  | 7.3 | 4.8 | 7.9  | 6   |     | 52         |
| 54         | 11.2 | 12.6 | 13   | 11.2 | 11.4 | 10.9 | 11.5 | 11.8 | 11.4 | 9.8  | 9.0  | 7.1 | 8.2  | 7.2 | 4.8 | 7.6  | 5.9 |     | 54         |
| 56         | 10.2 | 11.6 | 12.1 | 10.3 | 10.8 | 10.6 | 10.6 | 11.2 | 11.1 | 9.1  | 8.7  | 7.1 | 7.8  | 7.0 | 4.8 | 7.3  | 5.8 |     | 56         |
| 58         | 9.1  | 10.7 | 11.3 | 9.5  | 10.3 | 10.3 | 9.8  | 10.7 | 10.7 | 8.4  | 8.4  | 7.1 | 7.5  | 6.9 | 4.8 | 7    | 5.7 |     | 58         |
| 60         | 8    | 9.6  | 10.4 | 8.7  | 9.7  | 9.8  | 9.0  | 10.1 | 10.2 | 7.6  | 8.2  | 7.1 | 7.0  | 6.7 | 4.8 | 6.7  | 5.6 |     | 60         |
| 62         | 6.9  | 8.4  | 9.2  | 7.7  | 9.1  | 9.4  | 7.9  | 9.4  | 9.8  | 6.9  | 7.8  | 7.1 | 6.6  | 6.5 | 4.8 | 6.5  | 5.5 |     | 62         |
| 64         | 5.8  | 7.3  | 8    | 6.8  | 8.5  | 9    | 7.0  | 8.8  | 9.4  | 6.3  | 7.3  | 7.0 | 6.1  | 6.3 | 4.9 | 6.2  | 5.4 |     | 64         |
| 66         | 4.7  | 6.1  | 6.8  | 5.8  | 7.7  | 8.5  | 6.0  | 8.0  | 8.8  | 5.6  | 6.8  | 6.8 | 5.6  | 6.2 | 4.9 | 6    | 5.3 |     | 66         |
| 68         | 3.8  | 5    | 5.6  | 4.9  | 6.7  | 7.7  | 5.0  | 6.9  | 8.0  | 4.8  | 6.3  | 6.6 | 5.1  | 5.9 | 4.9 | 5.8  | 5.2 |     | 68         |
| 70         | 3.1  | 4    |      | 3.9  | 5.7  | 6.7  | 4.0  | 5.9  | 7.0  | 4.1  | 5.9  | 6.2 | 4.6  | 5.6 | 4.9 | 5.5  | 5.1 |     | 70         |
| 72         | 2.3  | 3.1  |      | 3    | 4.8  | 5.6  | 3.1  | 5.0  | 5.8  | 3.4  | 5.3  | 6.0 | 3.9  | 5.3 | 4.8 | 5    | 5   |     | 72         |
| 74         |      | 2.2  |      | 2.5  | 3.8  | 4.6  | 2.6  | 3.9  | 4.8  | 2.5  | 4.5  | 5.5 | 3.2  | 5.0 | 4.7 | 4.4  | 4.8 |     | 74         |
| 76         |      |      |      | 2    | 3    |      | 2.1  | 3.1  |      | 1.8  | 3.7  | 4.7 | 2.5  | 4.7 | 4.6 | 3.6  | 4.6 |     | 76         |
| 78         |      |      |      |      | 2.4  |      |      | 2.5  |      |      | 3.0  | 3.9 | 1.9  | 4.3 | 4.4 | 2.7  | 4.5 |     | 78         |
| 80         |      |      |      |      | 1.8  |      |      | 1.9  |      |      | 2.1  | 3.1 |      | 3.6 | 4.3 | 2.0  | 4.3 |     | 80         |
| 82         |      |      |      |      |      |      |      |      |      |      |      | 2.2 |      | 2.9 | 3.7 |      | 4.1 |     | 82         |
| 84         |      |      |      |      |      |      |      |      |      |      |      |     |      | 2.3 | 3.0 |      | 3.2 |     | 84         |
| 86         |      |      |      |      |      |      |      |      |      |      |      |     |      | 1.6 | 2.4 |      | 2.5 |     | 86         |
| 88         |      |      |      |      |      |      |      |      |      |      |      |     |      |     | 1.8 |      |     |     | 88         |

# Jib Operating Range

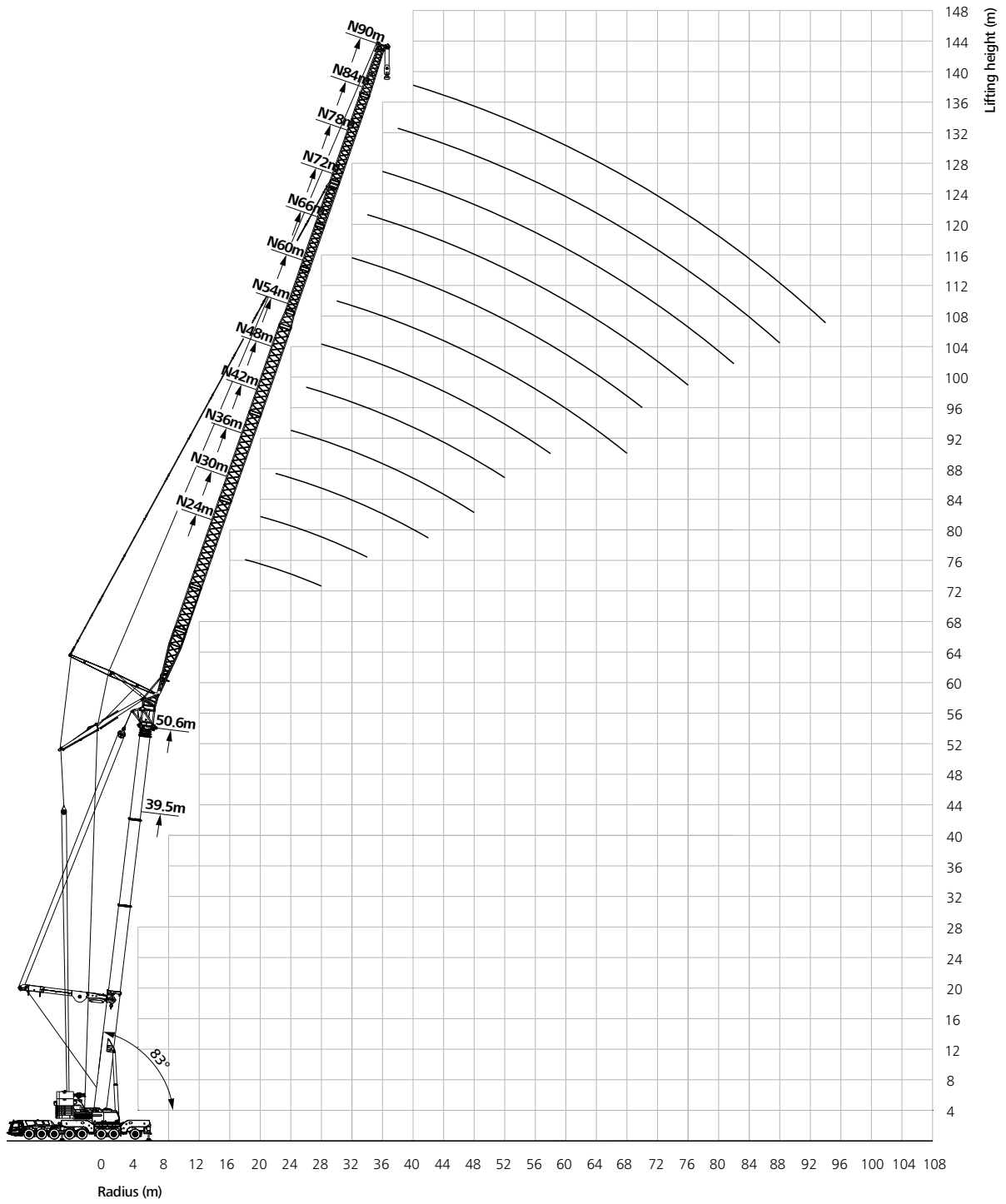

# Load Chart - Tower Jib

Unit: t

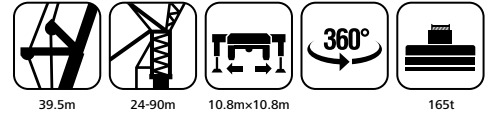

| Working radius (m) | 24   | 30   | 36   | 42   | 48   | 54   | 60   | 66   | 72   | 78   | 84   | 90   | Working radius (m) |
|--------------------|------|------|------|------|------|------|------|------|------|------|------|------|--------------------|
| 16                 | 87.0 |      |      |      |      |      |      |      |      |      |      |      | 16                 |
| 18                 | 83.0 | 78.9 |      |      |      |      |      |      |      |      |      |      | 18                 |
| 20                 | 79.4 | 73.6 | 69.4 |      |      |      |      |      |      |      |      |      | 20                 |
| 22                 | 74.0 | 69.4 | 65.2 | 58.8 |      |      |      |      |      |      |      |      | 22                 |
| 24                 | 68.5 | 64.1 | 61.1 | 56.7 | 47   |      |      |      |      |      |      |      | 24                 |
| 26                 | 61.9 | 60.9 | 57.9 | 54.7 | 46   | 37   |      |      |      |      |      |      | 26                 |
| 28                 |      | 56.6 | 54.8 | 52.6 | 45   | 36.5 | 30   |      |      |      |      |      | 28                 |
| 30                 |      | 52.9 | 51.2 | 49.5 | 44.5 | 35.5 | 29.7 | 31.2 |      |      |      |      | 30                 |
| 32                 |      | 48.7 | 48.1 | 46.5 | 43.5 | 35   | 29.4 | 30.8 | 24.6 |      |      |      | 32                 |
| 34                 |      |      | 44.9 | 43.4 | 42   | 34.5 | 29   | 30.4 | 23.8 | 20.6 |      |      | 34                 |
| 36                 |      |      | 42.4 | 40.9 | 40   | 34   | 28.7 | 30.1 | 23.0 | 20.3 | 15.7 |      | 36                 |
| 38                 |      |      | 39.8 | 38.3 | 37.5 | 33.5 | 28.4 | 29.8 | 22.4 | 20.0 | 15.3 | 13.3 | 38                 |
| 40                 |      |      |      | 36.3 | 35   | 32.5 | 28.2 | 29.6 | 21.8 | 19.7 | 14.8 | 13.2 | 40                 |
| 42                 |      |      |      | 34.3 | 33.5 | 32   | 27.9 | 29.3 | 21.2 | 19.2 | 14.4 | 12.8 | 42                 |
| 44                 |      |      |      | 32.2 | 31.5 | 31   | 27.6 | 28.9 | 20.5 | 18.7 | 14   | 12.4 | 44                 |
| 46                 |      |      |      | 30.0 | 29.8 | 29.4 | 27.3 | 28.6 | 19.9 | 18.3 | 13.6 | 12.1 | 46                 |
| 48                 |      |      |      |      | 28.3 | 27.9 | 27.1 | 28.4 | 19.3 | 18.0 | 13.3 | 11.8 | 48                 |
| 50                 |      |      |      |      | 27   | 26.6 | 26.1 | 27.4 | 18.8 | 17.6 | 12.9 | 11.5 | 50                 |
| 52                 |      |      |      |      |      | 25.3 | 24.8 | 26.0 | 18.4 | 17.3 | 12.6 | 11.2 | 52                 |
| 54                 |      |      |      |      |      | 24.1 | 23.6 | 24.7 | 17.9 | 16.9 | 12.3 | 10.9 | 54                 |
| 56                 |      |      |      |      |      | 23   | 22.5 | 23.6 | 17.6 | 16.6 | 11.9 | 10.7 | 56                 |
| 58                 |      |      |      |      |      |      | 21.5 | 22.5 | 17.2 | 16.3 | 11.6 | 10.4 | 58                 |
| 60                 |      |      |      |      |      |      | 20.6 | 21.6 | 16.9 | 16.0 | 11.4 | 10.1 | 60                 |
| 62                 |      |      |      |      |      |      | 19.7 | 20.7 | 16.5 | 15.7 | 11.1 | 9.9  | 62                 |
| 64                 |      |      |      |      |      |      | 18.9 | 19.8 | 16.2 | 15.5 | 10.9 | 9.7  | 64                 |
| 66                 |      |      |      |      |      |      | 17.4 | 18.2 | 16.0 | 15.1 | 10.7 | 9.5  | 66                 |
| 68                 |      |      |      |      |      |      |      | 15.2 | 15.8 | 14.9 | 10.4 | 9.3  | 68                 |
| 70                 |      |      |      |      |      |      |      |      | 15.6 | 14.7 | 10.2 | 9.2  | 70                 |
| 72                 |      |      |      |      |      |      |      |      | 15.2 | 14.4 | 10   | 9    | 72                 |
| 74                 |      |      |      |      |      |      |      |      | 12.9 | 14.3 | 9.8  | 8.9  | 74                 |
| 76                 |      |      |      |      |      |      |      |      |      | 14.1 | 9.6  | 8.7  | 76                 |
| 78                 |      |      |      |      |      |      |      |      |      | 13.5 | 9.5  | 8.6  | 78                 |
| 80                 |      |      |      |      |      |      |      |      |      | 11.7 | 9.3  | 8.4  | 80                 |
| 82                 |      |      |      |      |      |      |      |      |      |      | 9.2  | 8.3  | 82                 |
| 84                 |      |      |      |      |      |      |      |      |      |      | 9.1  | 8.2  | 84                 |
| 86                 |      |      |      |      |      |      |      |      |      |      | 9.1  | 8.1  | 86                 |
| 88                 |      |      |      |      |      |      |      |      |      |      |      | 8    | 88                 |
| 90                 |      |      |      |      |      |      |      |      |      |      |      | 7.9  | 90                 |
| 92                 |      |      |      |      |      |      |      |      |      |      |      | 7.9  | 92                 |
| 94                 |      |      |      |      |      |      |      |      |      |      |      |      | 94                 |

# Load Chart - Tower Jib

Unit: t

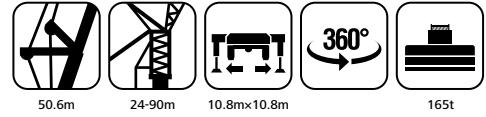

| Working radius (m) | 24   | 30   | 36   | 42   | 48   | 54   | 60   | 66   | 72   | 78   | 84   | 90  | Working radius (m) |
|--------------------|------|------|------|------|------|------|------|------|------|------|------|-----|--------------------|
| 16                 |      |      |      |      |      |      |      |      |      |      |      |     | 16                 |
| 18                 | 79.9 |      |      |      |      |      |      |      |      |      |      |     | 18                 |
| 20                 | 73.5 | 67.2 |      |      |      |      |      |      |      |      |      |     | 20                 |
| 22                 | 68.1 | 64.0 | 57.1 |      |      |      |      |      |      |      |      |     | 22                 |
| 24                 | 64.9 | 59.8 | 53.9 | 47.8 |      |      |      |      |      |      |      |     | 24                 |
| 26                 | 61.7 | 55.5 | 51.8 | 45.7 | 40   |      |      |      |      |      |      |     | 26                 |
| 28                 | 55.0 | 52.9 | 49.2 | 44.1 | 39   | 31.5 |      |      |      |      |      |     | 28                 |
| 30                 |      | 50.2 | 46.1 | 42.6 | 37.5 | 31.5 | 25.3 |      |      |      |      |     | 30                 |
| 32                 |      | 47.6 | 44.0 | 41.0 | 36.5 | 31.5 | 25.3 | 26.6 |      |      |      |     | 32                 |
| 34                 |      | 44.9 | 41.9 | 39.0 | 35.5 | 31.5 | 25.3 | 26.6 | 20.9 |      |      |     | 34                 |
| 36                 |      |      | 39.8 | 36.9 | 34.5 | 31   | 25.3 | 26.6 | 20.9 | 16.7 |      |     | 36                 |
| 38                 |      |      | 37.7 | 35.4 | 33   | 30   | 25.3 | 26.6 | 20.9 | 16.6 | 13   |     | 38                 |
| 40                 |      |      | 35.7 | 34.3 | 31.5 | 29.3 | 25.2 | 26.4 | 20.9 | 16.6 | 13   | 9.9 | 40                 |
| 42                 |      |      | 34.0 | 32.3 | 30.5 | 28.6 | 24.9 | 26.1 | 20.6 | 16.6 | 13   | 9.9 | 42                 |
| 44                 |      |      |      | 30.8 | 29.5 | 27.6 | 24.5 | 25.7 | 19.9 | 16.6 | 13   | 9.9 | 44                 |
| 46                 |      |      |      | 29.0 | 28   | 26.7 | 24.2 | 25.4 | 19.4 | 16.6 | 12.8 | 9.9 | 46                 |
| 48                 |      |      |      | 27.5 | 26.6 | 25.9 | 23.4 | 24.6 | 18.9 | 16.6 | 12.5 | 9.9 | 48                 |
| 50                 |      |      |      |      |      | 24.8 | 22.5 | 23.6 | 18.5 | 16.6 | 12.3 | 9.9 | 50                 |
| 52                 |      |      |      |      |      | 23.6 | 21.7 | 22.8 | 18.0 | 16.6 | 12   | 9.9 | 52                 |
| 54                 |      |      |      |      |      | 22.5 | 20.9 | 21.9 | 17.7 | 16.4 | 11.8 | 9.9 | 54                 |
| 56                 |      |      |      |      |      | 21.5 | 20.1 | 21.1 | 17.3 | 16.1 | 11.6 | 9.9 | 56                 |
| 58                 |      |      |      |      |      | 20.5 | 19.3 | 20.2 | 17.0 | 15.8 | 11.4 | 9.9 | 58                 |
| 60                 |      |      |      |      |      |      | 18.6 | 19.5 | 16.7 | 15.6 | 11.1 | 9.9 | 60                 |
| 62                 |      |      |      |      |      |      | 17.9 | 18.8 | 16.4 | 15.3 | 10.9 | 9.9 | 62                 |
| 64                 |      |      |      |      |      |      | 17.3 | 18.1 | 15.8 | 14.7 | 10.7 | 9.8 | 64                 |
| 66                 |      |      |      |      |      |      | 16.7 | 17.5 | 15.3 | 14.1 | 10.5 | 9.7 | 66                 |
| 68                 |      |      |      |      |      |      | 16.1 | 16.9 | 14.8 | 13.6 | 10.3 | 9.5 | 68                 |
| 70                 |      |      |      |      |      |      |      | 16.1 | 14.2 | 13.1 | 10.1 | 9.3 | 70                 |
| 72                 |      |      |      |      |      |      |      |      | 13.8 | 12.6 | 9.9  | 9.1 | 72                 |
| 74                 |      |      |      |      |      |      |      |      | 13.6 | 12.2 | 9.7  | 8.7 | 74                 |
| 76                 |      |      |      |      |      |      |      |      | 13.4 | 11.8 | 9.5  | 8.3 | 76                 |
| 78                 |      |      |      |      |      |      |      |      |      | 11.5 | 9.4  | 8   | 78                 |
| 80                 |      |      |      |      |      |      |      |      |      | 11.3 | 9.2  | 7.6 | 80                 |
| 82                 |      |      |      |      |      |      |      |      |      | 11.1 | 9.1  | 7.3 | 82                 |
| 84                 |      |      |      |      |      |      |      |      |      |      | 8.8  | 6.9 | 84                 |
| 86                 |      |      |      |      |      |      |      |      |      |      | 8.6  | 6.6 | 86                 |
| 88                 |      |      |      |      |      |      |      |      |      |      | 8.5  | 6.4 | 88                 |
| 90                 |      |      |      |      |      |      |      |      |      |      |      | 6.1 | 90                 |
| 92                 |      |      |      |      |      |      |      |      |      |      |      | 5.9 | 92                 |
| 94                 |      |      |      |      |      |      |      |      |      |      |      | 5.7 | 94                 |

# Load Chart - Tower Jib

Unit: t

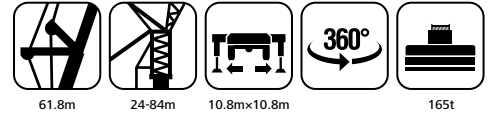

| Working radius (m) | 24   | 30   | 36   | 42   | 48   | 54   | 60   | 66   | 72   | 78   | 84  | Working radius (m) |
|--------------------|------|------|------|------|------|------|------|------|------|------|-----|--------------------|
| 20                 | 58.8 |      |      |      |      |      |      |      |      |      |     | 20                 |
| 22                 | 55.1 | 50.7 |      |      |      |      |      |      |      |      |     | 22                 |
| 24                 | 51.9 | 48.0 | 44.2 |      |      |      |      |      |      |      |     | 24                 |
| 26                 | 48.6 | 44.9 | 42.1 | 36.7 |      |      |      |      |      |      |     | 26                 |
| 28                 | 45.4 | 42.2 | 40.0 | 35.1 |      |      |      |      |      |      |     | 28                 |
| 30                 |      | 40.1 | 37.9 | 34.1 | 29.1 |      |      |      |      |      |     | 30                 |
| 32                 |      | 37.4 | 35.8 | 32.5 | 28.4 | 23.2 |      |      |      |      |     | 32                 |
| 34                 |      | 35.3 | 33.7 | 31.5 | 27.3 | 23.2 | 17.3 | 18.2 |      |      |     | 34                 |
| 36                 |      | 33.0 | 32.1 | 30.1 | 26.4 | 23.1 | 17.3 | 18.2 | 13.4 |      |     | 36                 |
| 38                 |      |      | 30.4 | 29.0 | 25.5 | 22.7 | 17.4 | 18.3 | 13.5 | 10.0 |     | 38                 |
| 40                 |      |      | 28.8 | 27.6 | 24.6 | 22.1 | 17.4 | 18.3 | 13.5 | 10.0 | 7.2 | 40                 |
| 42                 |      |      | 27.0 | 26.2 | 23.8 | 21.4 | 17.4 | 18.3 | 13.5 | 10.0 | 7.3 | 42                 |
| 44                 |      |      |      | 25.0 | 22.9 | 20.8 | 17.4 | 18.3 | 13.4 | 10.0 | 7.3 | 44                 |
| 46                 |      |      |      | 23.8 | 21.8 | 20.2 | 17.4 | 18.3 | 13.4 | 10.0 | 7.3 | 46                 |
| 48                 |      |      |      | 22.3 | 20.8 | 19.6 | 16.9 | 17.7 | 13.4 | 10.0 | 7.3 | 48                 |
| 50                 |      |      |      | 21.0 | 19.9 | 18.9 | 16.3 | 17.1 | 13.4 | 10.0 | 7.3 | 50                 |
| 52                 |      |      |      |      | 19   | 18.2 | 15.6 | 16.4 | 13.4 | 10.0 | 7.3 | 52                 |
| 54                 |      |      |      |      | 18.3 | 17.4 | 14.9 | 15.6 | 12.9 | 10.0 | 7.3 | 54                 |
| 56                 |      |      |      |      |      | 16.7 | 14.3 | 15.0 | 12.3 | 10.0 | 7.3 | 56                 |
| 58                 |      |      |      |      |      | 16   | 13.7 | 14.4 | 11.7 | 10.0 | 7.3 | 58                 |
| 60                 |      |      |      |      |      | 15.3 | 13.1 | 13.7 | 11.2 | 9.6  | 7.3 | 60                 |
| 62                 |      |      |      |      |      |      | 12.5 | 13.1 | 10.6 | 9.1  | 7   | 62                 |
| 64                 |      |      |      |      |      |      | 11.9 | 12.5 | 10.1 | 8.6  | 6.6 | 64                 |
| 66                 |      |      |      |      |      |      | 11.4 | 12.0 | 9.6  | 8.2  | 6.2 | 66                 |
| 68                 |      |      |      |      |      |      | 11   | 11.5 | 9.1  | 7.7  | 5.9 | 68                 |
| 70                 |      |      |      |      |      |      | 10.6 | 11.1 | 8.7  | 7.3  | 5.6 | 70                 |
| 72                 |      |      |      |      |      |      |      |      | 8.3  | 6.9  | 5.3 | 72                 |
| 74                 |      |      |      |      |      |      |      |      | 7.8  | 6.5  | 5   | 74                 |
| 76                 |      |      |      |      |      |      |      |      | 7.6  | 6.1  | 4.7 | 76                 |
| 78                 |      |      |      |      |      |      |      |      | 7.1  | 5.8  | 4.4 | 78                 |
| 80                 |      |      |      |      |      |      |      |      |      | 5.5  | 4.1 | 80                 |
| 82                 |      |      |      |      |      |      |      |      |      | 5.3  | 3.9 | 82                 |
| 84                 |      |      |      |      |      |      |      |      |      | 5.1  | 3.7 | 84                 |
| 86                 |      |      |      |      |      |      |      |      |      |      | 3.5 | 86                 |
| 88                 |      |      |      |      |      |      |      |      |      |      | 3.3 | 88                 |
| 90                 |      |      |      |      |      |      |      |      |      |      | 3.2 | 90                 |

## Load Chart - Tower Jib

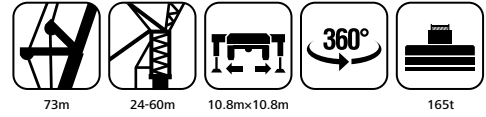

Unit: t

| Working radius (m) | 24   | 30   | 36   | 42   | 48   | 54   | 60  | Working radius (m) |
|--------------------|------|------|------|------|------|------|-----|--------------------|
| 20                 |      |      |      |      |      |      |     | 20                 |
| 22                 | 43.7 |      |      |      |      |      |     | 22                 |
| 24                 | 41.7 | 35.2 |      |      |      |      |     | 24                 |
| 26                 | 39.0 | 33.6 | 29.8 |      |      |      |     | 26                 |
| 28                 | 36.8 | 31.7 | 28.3 |      |      |      |     | 28                 |
| 30                 | 33.0 | 30.1 | 26.9 | 23.8 |      |      |     | 30                 |
| 32                 |      | 28.6 | 25.6 | 22.6 | 19.4 |      |     | 32                 |
| 34                 |      | 27.3 | 24.4 | 21.7 | 18.7 | 14.0 |     | 34                 |
| 36                 |      | 26.0 | 23.3 | 20.7 | 18.0 | 14.2 | 9.5 | 36                 |
| 38                 |      |      | 22.3 | 19.8 | 17.2 | 14.3 | 9.7 | 38                 |
| 40                 |      |      | 21.5 | 19.0 | 16.6 | 13.9 | 9.7 | 40                 |
| 42                 |      |      | 20.5 | 18.3 | 15.9 | 13.4 | 9.7 | 42                 |
| 44                 |      |      | 19.8 | 17.6 | 15.3 | 12.9 | 9.7 | 44                 |
| 46                 |      |      |      | 16.9 | 14.7 | 12.4 | 9.4 | 46                 |
| 48                 |      |      |      | 16.3 | 14.2 | 11.9 | 8.9 | 48                 |
| 50                 |      |      |      | 15.7 | 13.7 | 11.4 | 8.4 | 50                 |
| 52                 |      |      |      |      | 13.3 | 10.8 | 7.9 | 52                 |
| 54                 |      |      |      |      | 12.8 | 10.3 | 7.4 | 54                 |
| 56                 |      |      |      |      |      | 9.8  | 7.0 | 56                 |
| 58                 |      |      |      |      |      | 9.3  | 6.6 | 58                 |
| 60                 |      |      |      |      |      | 8.8  | 6.3 | 60                 |
| 62                 |      |      |      |      |      |      | 5.9 | 62                 |
| 64                 |      |      |      |      |      |      | 5.6 | 64                 |
| 66                 |      |      |      |      |      |      | 5.2 | 66                 |
| 68                 |      |      |      |      |      |      | 5.0 | 68                 |
| 70                 |      |      |      |      |      |      | 4.7 | 70                 |
| 72                 |      |      |      |      |      |      | 4.5 | 72                 |
| 74                 |      |      |      |      |      |      |     | 74                 |
| 76                 |      |      |      |      |      |      |     | 76                 |
| 78                 |      |      |      |      |      |      |     | 78                 |
| 80                 |      |      |      |      |      |      |     | 80                 |
| 82                 |      |      |      |      |      |      |     | 82                 |
| 84                 |      |      |      |      |      |      |     | 84                 |
| 86                 |      |      |      |      |      |      |     | 86                 |
| 88                 |      |      |      |      |      |      |     | 88                 |
| 90                 |      |      |      |      |      |      |     | 90                 |

# Load Chart - Tower Jib

Unit: t

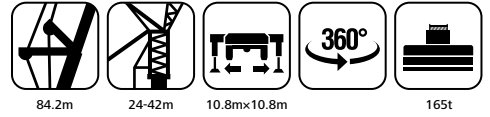

| Working radius (m) | 24   | 30   | 36   | 42   | Working radius (m) |
|--------------------|------|------|------|------|--------------------|
| 20                 |      |      |      |      | 20                 |
| 22                 |      |      |      |      | 22                 |
| 24                 | 27.2 |      |      |      | 24                 |
| 26                 | 25.6 | 20.1 |      |      | 26                 |
| 28                 | 24.2 | 20.1 |      |      | 28                 |
| 30                 |      | 19.0 | 16.2 |      | 30                 |
| 32                 |      | 18.1 | 15.3 | 13.2 | 32                 |
| 34                 |      |      | 14.4 | 12.4 | 34                 |
| 36                 |      |      | 13.7 | 11.7 | 36                 |
| 38                 |      |      | 13.0 | 11.1 | 38                 |
| 40                 |      |      |      | 10.5 | 40                 |
| 42                 |      |      |      | 10.0 | 42                 |
| 44                 |      |      |      | 9.3  | 44                 |
| 46                 |      |      |      |      | 46                 |
| 48                 |      |      |      |      | 48                 |
| 50                 |      |      |      |      | 50                 |
| 52                 |      |      |      |      | 52                 |
| 54                 |      |      |      |      | 54                 |
| 56                 |      |      |      |      | 56                 |
| 58                 |      |      |      |      | 58                 |
| 60                 |      |      |      |      | 60                 |
| 62                 |      |      |      |      | 62                 |
| 64                 |      |      |      |      | 64                 |
| 66                 |      |      |      |      | 66                 |
| 68                 |      |      |      |      | 68                 |
| 70                 |      |      |      |      | 70                 |
| 72                 |      |      |      |      | 72                 |
| 74                 |      |      |      |      | 74                 |
| 76                 |      |      |      |      | 76                 |
| 78                 |      |      |      |      | 78                 |
| 80                 |      |      |      |      | 80                 |
| 82                 |      |      |      |      | 82                 |
| 84                 |      |      |      |      | 84                 |
| 86                 |      |      |      |      | 86                 |
| 88                 |      |      |      |      | 88                 |
| 90                 |      |      |      |      | 90                 |

# Jib Operating Range

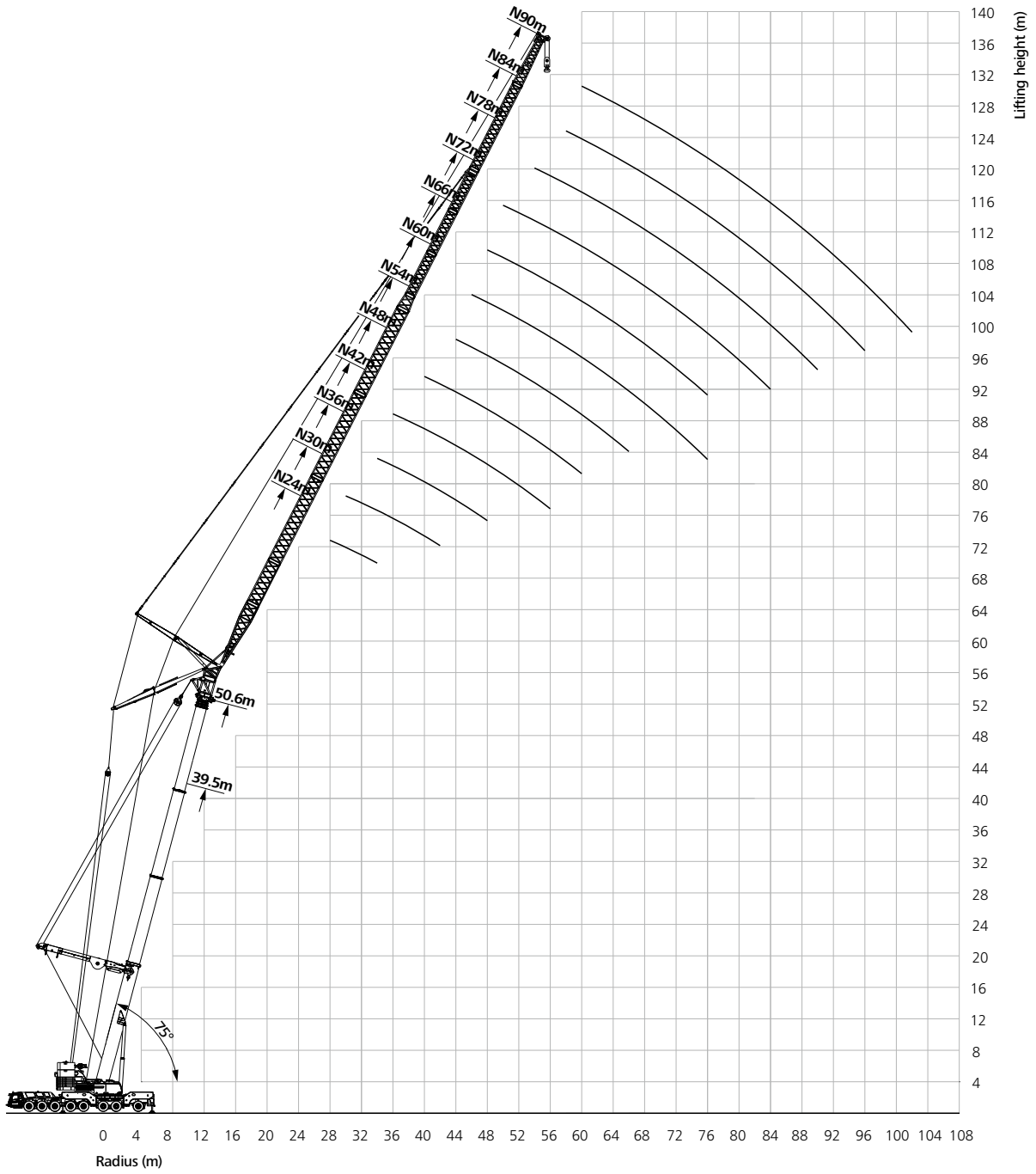

# Load Chart - Tower Jib

Unit: t

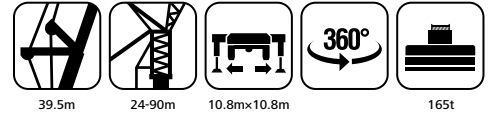

| Working radius (m) | 24   | 30   | 36   | 42   | 48   | 54   | 60   | 66   | 72   | 78   | 84   | 90   | Working radius (m) |
|--------------------|------|------|------|------|------|------|------|------|------|------|------|------|--------------------|
| 24                 | 62.9 |      |      |      |      |      |      |      |      |      |      |      | 24                 |
| 26                 | 57.6 |      |      |      |      |      |      |      |      |      |      |      | 26                 |
| 28                 | 53.8 | 50.7 |      |      |      |      |      |      |      |      |      |      | 28                 |
| 30                 | 50.1 | 46.9 | 45.2 |      |      |      |      |      |      |      |      |      | 30                 |
| 32                 | 45.0 | 43.8 | 42.1 |      |      |      |      |      |      |      |      |      | 32                 |
| 34                 |      | 41.1 | 39.5 | 37.7 |      |      |      |      |      |      |      |      | 34                 |
| 36                 |      | 38.5 | 36.9 | 35.7 | 34   |      |      |      |      |      |      |      | 36                 |
| 38                 |      | 36.3 | 34.2 | 33.1 | 32   |      |      |      |      |      |      |      | 38                 |
| 40                 |      |      | 32.7 | 31.5 | 30   | 29.7 |      |      |      |      |      |      | 40                 |
| 42                 |      |      | 30.7 | 29.5 | 28.5 | 28   | 27.3 |      |      |      |      |      | 42                 |
| 44                 |      |      | 29.0 | 27.9 | 26.9 | 26.4 | 25.8 | 27.1 |      |      |      |      | 44                 |
| 46                 |      |      | 28.0 | 26.4 | 25.4 | 25   | 24.4 | 25.6 |      |      |      |      | 46                 |
| 48                 |      |      |      | 25.0 | 24.1 | 23.7 | 23.1 | 24.3 | 20.9 |      |      |      | 48                 |
| 50                 |      |      |      | 23.8 | 22.9 | 22.4 | 21.9 | 23.0 | 20.4 | 18.9 |      |      | 50                 |
| 52                 |      |      |      | 22.6 | 21.8 | 21.3 | 20.7 | 21.7 | 19.9 | 18.5 | 13.5 |      | 52                 |
| 54                 |      |      |      |      | 20.7 | 20.3 | 19.7 | 20.7 | 19.4 | 18.1 | 13.1 |      | 54                 |
| 56                 |      |      |      |      | 19.8 | 19.3 | 18.8 | 19.7 | 18.8 | 17.7 | 12.8 | 11.1 | 56                 |
| 58                 |      |      |      |      |      | 18.4 | 17.9 | 18.8 | 18.2 | 17.3 | 12.5 | 10.9 | 58                 |
| 60                 |      |      |      |      |      | 17.6 | 17.1 | 18.0 | 17.3 | 16.5 | 12.2 | 10.7 | 60                 |
| 62                 |      |      |      |      |      | 16.8 | 16.3 | 17.1 | 16.4 | 15.6 | 11.9 | 10.4 | 62                 |
| 64                 |      |      |      |      |      |      | 15.6 | 16.4 | 15.7 | 14.9 | 11.6 | 10.2 | 64                 |
| 66                 |      |      |      |      |      |      | 14.9 | 15.6 | 15.0 | 14.2 | 11.4 | 10   | 66                 |
| 68                 |      |      |      |      |      |      | 14.2 | 14.9 | 14.4 | 13.6 | 11.1 | 9.8  | 68                 |
| 70                 |      |      |      |      |      |      | 13.6 | 14.3 | 13.7 | 13.0 | 10.9 | 9.7  | 70                 |
| 72                 |      |      |      |      |      |      | 13.1 | 13.8 | 13.1 | 12.3 | 10.7 | 9.5  | 72                 |
| 74                 |      |      |      |      |      |      |      | 13.1 | 12.6 | 11.7 | 10.5 | 9.3  | 74                 |
| 76                 |      |      |      |      |      |      |      |      | 12.0 | 11.2 | 10.3 | 9.1  | 76                 |
| 78                 |      |      |      |      |      |      |      |      | 11.6 | 10.7 | 10   | 9    | 78                 |
| 80                 |      |      |      |      |      |      |      |      | 11.1 | 10.3 | 9.6  | 8.9  | 80                 |
| 82                 |      |      |      |      |      |      |      |      |      | 9.9  | 9.2  | 8.6  | 82                 |
| 84                 |      |      |      |      |      |      |      |      |      | 9.4  | 8.7  | 8.2  | 84                 |
| 86                 |      |      |      |      |      |      |      |      |      | 9.0  | 8.3  | 7.8  | 86                 |
| 88                 |      |      |      |      |      |      |      |      |      |      | 8    | 7.5  | 88                 |
| 90                 |      |      |      |      |      |      |      |      |      |      | 7.6  | 7.1  | 90                 |
| 92                 |      |      |      |      |      |      |      |      |      |      | 7.3  | 6.8  | 92                 |
| 94                 |      |      |      |      |      |      |      |      |      |      |      | 6.4  | 94                 |
| 96                 |      |      |      |      |      |      |      |      |      |      |      | 6.1  | 96                 |
| 98                 |      |      |      |      |      |      |      |      |      |      |      | 5.8  | 98                 |
| 100                |      |      |      |      |      |      |      |      |      |      |      |      | 100                |
| 102                |      |      |      |      |      |      |      |      |      |      |      |      | 102                |

## Load Chart - Tower Jib

Unit: t

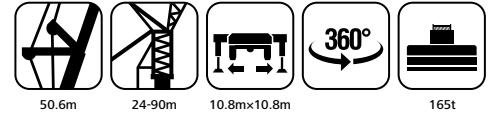

| Working radius (m) | 24   | 30   | 36   | 42   | 48   | 54   | 60   | 66   | 72   | 78   | 84   | 90  | Working radius (m) |
|--------------------|------|------|------|------|------|------|------|------|------|------|------|-----|--------------------|
| 24                 |      |      |      |      |      |      |      |      |      |      |      |     | 24                 |
| 26                 |      |      |      |      |      |      |      |      |      |      |      |     | 26                 |
| 28                 | 48.5 |      |      |      |      |      |      |      |      |      |      |     | 28                 |
| 30                 | 45.3 | 43.2 |      |      |      |      |      |      |      |      |      |     | 30                 |
| 32                 | 42.7 | 40.0 |      |      |      |      |      |      |      |      |      |     | 32                 |
| 34                 | 40.0 | 37.4 | 35.4 |      |      |      |      |      |      |      |      |     | 34                 |
| 36                 |      | 35.2 | 33.3 | 32.3 |      |      |      |      |      |      |      |     | 36                 |
| 38                 |      | 33.1 | 31.2 | 30.2 |      |      |      |      |      |      |      |     | 38                 |
| 40                 |      | 31.0 | 29.4 | 28.4 | 26.9 |      |      |      |      |      |      |     | 40                 |
| 42                 |      | 29.0 | 27.8 | 26.7 | 25.4 |      |      |      |      |      |      |     | 42                 |
| 44                 |      |      | 26.2 | 25.2 | 23.9 | 23.4 |      |      |      |      |      |     | 44                 |
| 46                 |      |      | 24.8 | 23.8 | 22.6 | 22.1 | 21.4 |      |      |      |      |     | 46                 |
| 48                 |      |      | 23.6 | 22.6 | 21.4 | 20.9 | 20.2 | 21.2 |      |      |      |     | 48                 |
| 50                 |      |      |      | 21.5 | 20.3 | 19.8 | 19.2 | 20.2 | 18.8 |      |      |     | 50                 |
| 52                 |      |      |      | 20.3 | 19.3 | 18.8 | 18.1 | 19.0 | 17.9 |      |      |     | 52                 |
| 54                 |      |      |      | 19.4 | 18.3 | 17.8 | 17.2 | 18.1 | 17.1 | 15.9 |      |     | 54                 |
| 56                 |      |      |      | 18.5 | 17.4 | 17   | 16.3 | 17.1 | 16.3 | 15.2 |      |     | 56                 |
| 58                 |      |      |      |      | 16.6 | 16.1 | 15.5 | 16.3 | 15.5 | 14.4 | 12.2 |     | 58                 |
| 60                 |      |      |      |      | 15.8 | 15.4 | 14.8 | 15.6 | 14.8 | 13.8 | 12   | 9.8 | 60                 |
| 62                 |      |      |      |      |      | 14.7 | 14.1 | 14.8 | 14.2 | 13.2 | 11.5 | 9.3 | 62                 |
| 64                 |      |      |      |      |      | 14   | 13.4 | 14.1 | 13.6 | 12.6 | 11   | 8.9 | 64                 |
| 66                 |      |      |      |      |      | 13.3 | 12.8 | 13.4 | 12.9 | 12.1 | 10.5 | 8.4 | 66                 |
| 68                 |      |      |      |      |      |      | 12.2 | 12.8 | 12.3 | 11.5 | 10   | 7.9 | 68                 |
| 70                 |      |      |      |      |      |      | 11.6 | 12.2 | 11.7 | 10.9 | 9.6  | 7.5 | 70                 |
| 72                 |      |      |      |      |      |      | 11.1 | 11.7 | 11.2 | 10.3 | 9.2  | 7.1 | 72                 |
| 74                 |      |      |      |      |      |      | 10.6 | 11.1 | 10.7 | 9.9  | 8.8  | 6.7 | 74                 |
| 76                 |      |      |      |      |      |      | 10.2 | 10.7 | 10.1 | 9.4  | 8.4  | 6.4 | 76                 |
| 78                 |      |      |      |      |      |      |      |      | 9.7  | 8.9  | 8    | 6.1 | 78                 |
| 80                 |      |      |      |      |      |      |      |      | 9.3  | 8.5  | 7.7  | 5.8 | 80                 |
| 82                 |      |      |      |      |      |      |      |      | 8.9  | 8.1  | 7.3  | 5.5 | 82                 |
| 84                 |      |      |      |      |      |      |      |      | 8.2  | 7.8  | 7    | 5.2 | 84                 |
| 86                 |      |      |      |      |      |      |      |      |      | 7.4  | 6.6  | 5   | 86                 |
| 88                 |      |      |      |      |      |      |      |      |      | 7.0  | 6.3  | 4.7 | 88                 |
| 90                 |      |      |      |      |      |      |      |      |      | 6.6  | 6    | 4.5 | 90                 |
| 92                 |      |      |      |      |      |      |      |      |      |      | 5.7  | 4.2 | 92                 |
| 94                 |      |      |      |      |      |      |      |      |      |      | 5.4  | 4   | 94                 |
| 96                 |      |      |      |      |      |      |      |      |      |      | 5.1  | 3.8 | 96                 |
| 98                 |      |      |      |      |      |      |      |      |      |      |      | 3.6 | 98                 |
| 100                |      |      |      |      |      |      |      |      |      |      |      | 3.5 | 100                |
| 102                |      |      |      |      |      |      |      |      |      |      |      | 3.3 | 102                |

# Load Chart - Tower Jib

Unit: t

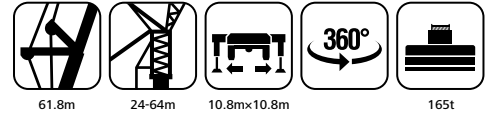

| Working radius (m) | 24   | 30   | 36   | 42   | 48   | 54   | 60   | 66   | 72  | 78  | 84  | Working radius (m) |
|--------------------|------|------|------|------|------|------|------|------|-----|-----|-----|--------------------|
| 30                 | 38.5 |      |      |      |      |      |      |      |     |     |     | 30                 |
| 32                 | 36.4 |      |      |      |      |      |      |      |     |     |     | 32                 |
| 34                 | 34.2 | 32.6 |      |      |      |      |      |      |     |     |     | 34                 |
| 36                 | 32.7 | 30.6 |      |      |      |      |      |      |     |     |     | 36                 |
| 38                 |      | 29.1 | 27.8 |      |      |      |      |      |     |     |     | 38                 |
| 40                 |      | 27.7 | 26.3 | 24.6 |      |      |      |      |     |     |     | 40                 |
| 42                 |      | 26.4 | 25.0 | 23.3 |      |      |      |      |     |     |     | 42                 |
| 44                 |      | 25.6 | 23.9 | 22.1 | 19.3 |      |      |      |     |     |     | 44                 |
| 46                 |      |      | 22.8 | 21.0 | 18.3 |      |      |      |     |     |     | 46                 |
| 48                 |      |      | 21.5 | 20.0 | 17.4 | 16.4 |      |      |     |     |     | 48                 |
| 50                 |      |      | 20.5 | 19.1 | 16.6 | 15.6 | 13   | 13.7 |     |     |     | 50                 |
| 52                 |      |      |      | 18.3 | 15.8 | 14.8 | 12.3 | 12.9 |     |     |     | 52                 |
| 54                 |      |      |      | 17.4 | 15.1 | 14   | 11.6 | 12.2 | 9.7 |     |     | 54                 |
| 56                 |      |      |      | 16.7 | 14.4 | 13.4 | 11   | 11.6 | 9.0 |     |     | 56                 |
| 58                 |      |      |      | 16.0 | 13.8 | 12.8 | 10.4 | 10.9 | 8.5 | 6.8 |     | 58                 |
| 60                 |      |      |      |      | 13.2 | 12.2 | 9.8  | 10.3 | 8.0 | 6.4 | 4.3 | 60                 |
| 62                 |      |      |      |      | 12.6 | 11.7 | 9.3  | 9.8  | 7.5 | 6.0 | 4   | 62                 |
| 64                 |      |      |      |      |      | 11.1 | 8.8  | 9.3  | 7.1 | 5.5 | 3.8 | 64                 |
| 66                 |      |      |      |      |      | 10.6 | 8.4  | 8.8  | 6.6 | 5.1 | 3.5 | 66                 |
| 68                 |      |      |      |      |      | 10.1 | 7.9  | 8.3  | 6.3 | 4.7 | 3.2 | 68                 |
| 70                 |      |      |      |      |      |      | 7.5  | 7.9  | 5.9 | 4.5 | 3   | 70                 |
| 72                 |      |      |      |      |      |      | 7.1  | 7.5  | 5.6 | 4.2 | 2.8 | 72                 |
| 74                 |      |      |      |      |      |      | 6.7  | 7.0  | 5.3 | 4.0 | 2.6 | 74                 |
| 76                 |      |      |      |      |      |      | 6.4  | 6.7  | 5.0 | 3.8 | 2.4 | 76                 |
| 78                 |      |      |      |      |      |      | 6.1  | 6.4  | 4.7 | 3.5 | 2.2 | 78                 |
| 80                 |      |      |      |      |      |      |      |      | 4.4 | 3.3 | 2   | 80                 |
| 82                 |      |      |      |      |      |      |      |      | 4.1 | 3.1 | 1.8 | 82                 |
| 84                 |      |      |      |      |      |      |      |      | 3.9 | 2.9 | 1.6 | 84                 |
| 86                 |      |      |      |      |      |      |      |      | 3.7 | 2.7 | 1.5 | 86                 |
| 88                 |      |      |      |      |      |      |      |      |     | 2.5 | 1.3 | 88                 |
| 90                 |      |      |      |      |      |      |      |      |     | 2.4 | 1.1 | 90                 |
| 92                 |      |      |      |      |      |      |      |      |     | 2.2 | 1   | 92                 |

# Load Chart - Tower Jib

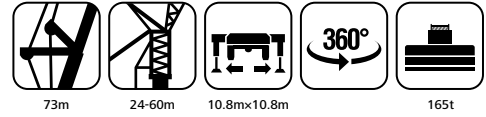

Unit: t

| Working radius (m) | 24   | 30   | 36   | 42   | 48   | 54  | 60  | Working radius (m) |
|--------------------|------|------|------|------|------|-----|-----|--------------------|
| 30                 |      |      |      |      |      |     |     | 30                 |
| 32                 |      |      |      |      |      |     |     | 32                 |
| 34                 | 28.9 |      |      |      |      |     |     | 34                 |
| 36                 | 27.2 |      |      |      |      |     |     | 36                 |
| 38                 | 25.8 | 22.4 |      |      |      |     |     | 38                 |
| 40                 | 23.4 | 21.4 |      |      |      |     |     | 40                 |
| 42                 |      | 20.3 | 18.4 |      |      |     |     | 42                 |
| 44                 |      | 19.3 | 17.5 |      |      |     |     | 44                 |
| 46                 |      | 18.5 | 16.6 | 14.9 |      |     |     | 46                 |
| 48                 |      |      | 15.7 | 14.2 | 12.1 |     |     | 48                 |
| 50                 |      |      | 15.0 | 13.3 | 11.5 |     |     | 50                 |
| 52                 |      |      | 14.3 | 12.7 | 10.9 | 7.7 |     | 52                 |
| 54                 |      |      | 13.7 | 12.1 | 10.3 | 7.2 | 4.1 | 54                 |
| 56                 |      |      |      | 11.4 | 9.8  | 6.7 | 3.8 | 56                 |
| 58                 |      |      |      | 10.8 | 9.3  | 6.2 | 3.5 | 58                 |
| 60                 |      |      |      | 10.3 | 8.8  | 5.8 | 3.3 | 60                 |
| 62                 |      |      |      |      | 8.4  | 5.5 | 3   | 62                 |
| 64                 |      |      |      |      | 7.9  | 5.2 | 2.8 | 64                 |
| 66                 |      |      |      |      | 7.5  | 4.9 | 2.6 | 66                 |
| 68                 |      |      |      |      |      | 4.6 | 2.4 | 68                 |
| 70                 |      |      |      |      |      | 4.3 | 2.2 | 70                 |
| 72                 |      |      |      |      |      | 4   | 2   | 72                 |
| 74                 |      |      |      |      |      |     | 1.8 | 74                 |
| 76                 |      |      |      |      |      |     | 1.6 | 76                 |
| 78                 |      |      |      |      |      |     | 1.4 | 78                 |
| 80                 |      |      |      |      |      |     | 1.3 | 80                 |
| 82                 |      |      |      |      |      |     | 1.2 | 82                 |
| 84                 |      |      |      |      |      |     |     | 84                 |
| 86                 |      |      |      |      |      |     |     | 86                 |
| 88                 |      |      |      |      |      |     |     | 88                 |
| 90                 |      |      |      |      |      |     |     | 90                 |
| 92                 |      |      |      |      |      |     |     | 92                 |

# Load Chart - Tower Jib

Unit: t

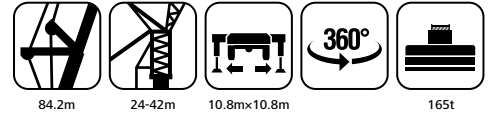

| Working radius (m) | 24   | 30   | 36  | 42  | Working radius (m) |
|--------------------|------|------|-----|-----|--------------------|
| 30                 |      |      |     |     | 30                 |
| 32                 |      |      |     |     | 32                 |
| 34                 |      |      |     |     | 34                 |
| 36                 |      |      |     |     | 36                 |
| 38                 | 16.6 |      |     |     | 38                 |
| 40                 | 15.9 |      |     |     | 40                 |
| 42                 |      | 11.8 |     |     | 42                 |
| 44                 |      | 11.2 |     |     | 44                 |
| 46                 |      | 10.7 | 8.8 |     | 46                 |
| 48                 |      |      | 8.3 |     | 48                 |
| 50                 |      |      | 7.8 | 6.0 | 50                 |
| 52                 |      |      |     | 5.5 | 52                 |
| 54                 |      |      |     | 5.1 | 54                 |
| 56                 |      |      |     | 4.8 | 56                 |
| 58                 |      |      |     |     | 58                 |
| 60                 |      |      |     |     | 60                 |
| 62                 |      |      |     |     | 62                 |
| 64                 |      |      |     |     | 64                 |
| 66                 |      |      |     |     | 66                 |
| 68                 |      |      |     |     | 68                 |
| 70                 |      |      |     |     | 70                 |
| 72                 |      |      |     |     | 72                 |
| 74                 |      |      |     |     | 74                 |
| 76                 |      |      |     |     | 76                 |
| 78                 |      |      |     |     | 78                 |
| 80                 |      |      |     |     | 80                 |
| 82                 |      |      |     |     | 82                 |
| 84                 |      |      |     |     | 84                 |
| 86                 |      |      |     |     | 86                 |
| 88                 |      |      |     |     | 88                 |
| 90                 |      |      |     |     | 90                 |
| 92                 |      |      |     |     | 92                 |

# Jib Operating Range

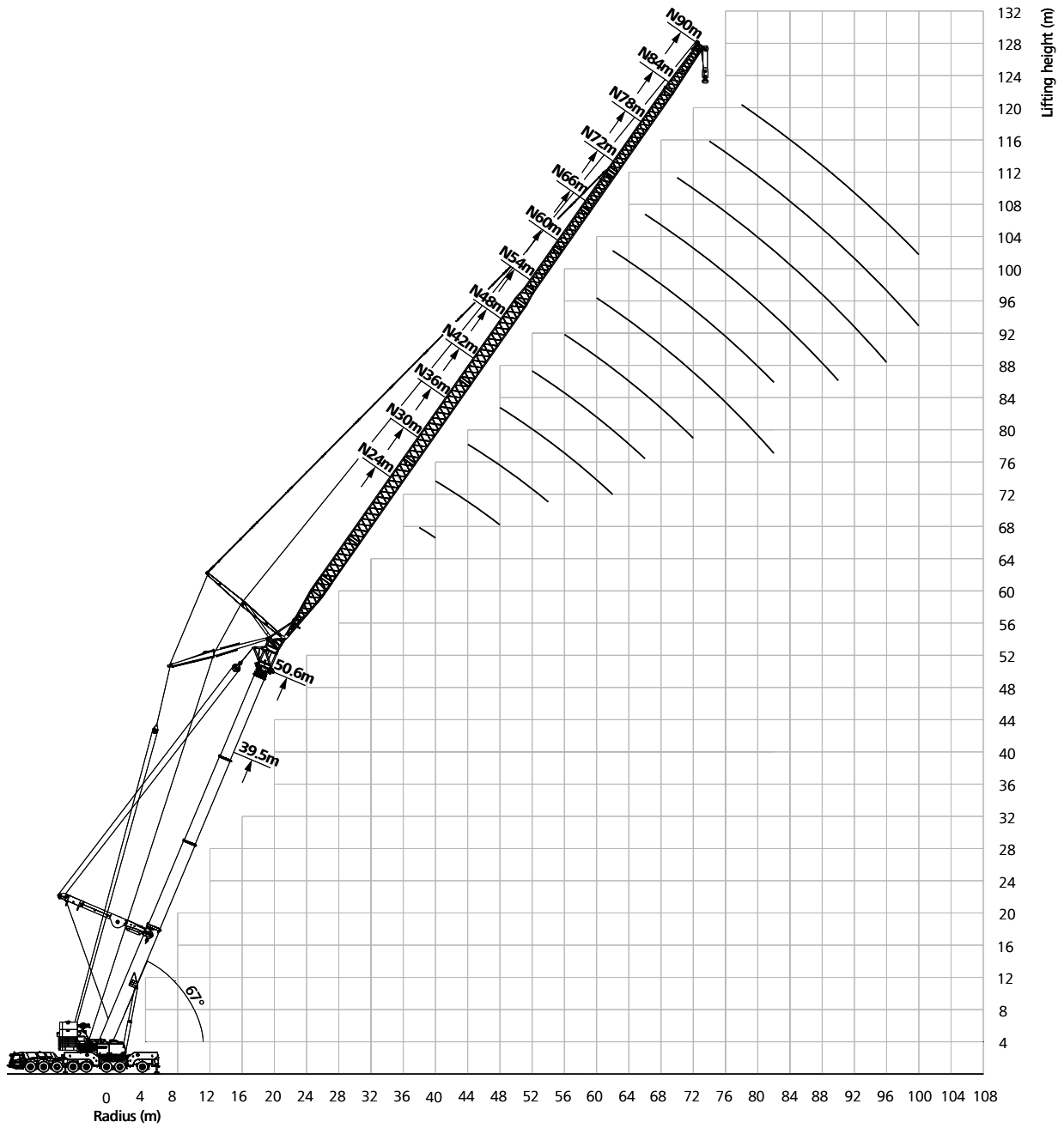

# Load Chart - Tower Jib

Unit: t

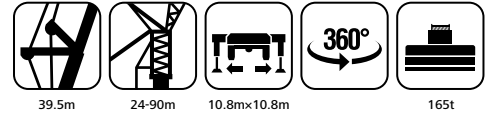

| Working radius (m) | 24   | 30   | 36   | 42   | 48   | 54   | 60   | 66   | 72   | 78   | 84  | 90  | Working radius (m) |
|--------------------|------|------|------|------|------|------|------|------|------|------|-----|-----|--------------------|
| 32                 | 40.7 |      |      |      |      |      |      |      |      |      |     |     | 32                 |
| 34                 | 38.1 |      |      |      |      |      |      |      |      |      |     |     | 34                 |
| 36                 | 35.9 | 33.6 |      |      |      |      |      |      |      |      |     |     | 36                 |
| 38                 |      | 31.5 |      |      |      |      |      |      |      |      |     |     | 38                 |
| 40                 |      | 29.7 | 28.1 |      |      |      |      |      |      |      |     |     | 40                 |
| 42                 |      | 28.0 | 26.5 |      |      |      |      |      |      |      |     |     | 42                 |
| 44                 |      | 26.5 | 25.1 | 24.0 |      |      |      |      |      |      |     |     | 44                 |
| 46                 |      |      | 23.7 | 22.7 |      |      |      |      |      |      |     |     | 46                 |
| 48                 |      |      | 22.5 | 21.5 | 20.4 |      |      |      |      |      |     |     | 48                 |
| 50                 |      |      | 21.0 | 20.4 | 19.4 |      |      |      |      |      |     |     | 50                 |
| 52                 |      |      |      | 19.4 | 18.4 | 17.9 |      |      |      |      |     |     | 52                 |
| 54                 |      |      |      | 18.4 | 17.5 | 17   |      |      |      |      |     |     | 54                 |
| 56                 |      |      |      | 17.5 | 16.6 | 16.1 | 15.5 |      |      |      |     |     | 56                 |
| 58                 |      |      |      | 16.7 | 15.8 | 15.3 | 14.7 | 15.5 |      |      |     |     | 58                 |
| 60                 |      |      |      |      | 15.1 | 14.6 | 14   | 14.7 |      |      |     |     | 60                 |
| 62                 |      |      |      |      | 14.4 | 13.9 | 13.3 | 14.0 | 13.5 |      |     |     | 62                 |
| 64                 |      |      |      |      |      | 13.2 | 12.7 | 13.3 | 12.8 | 12.0 |     |     | 64                 |
| 66                 |      |      |      |      |      | 12.6 | 12.1 | 12.7 | 12.1 | 11.4 |     |     | 66                 |
| 68                 |      |      |      |      |      | 12.1 | 11.5 | 12.1 | 11.5 | 10.8 | 9.9 |     | 68                 |
| 70                 |      |      |      |      |      |      | 11   | 11.6 | 11.0 | 10.2 | 9.4 |     | 70                 |
| 72                 |      |      |      |      |      |      | 10.5 | 11.0 | 10.5 | 9.7  | 8.9 | 8.4 | 72                 |
| 74                 |      |      |      |      |      |      | 10   | 10.5 | 9.9  | 9.2  | 8.4 | 7.9 | 74                 |
| 76                 |      |      |      |      |      |      | 9.6  | 10.1 | 9.5  | 8.7  | 8   | 7.5 | 76                 |
| 78                 |      |      |      |      |      |      | 9.1  | 9.6  | 9.1  | 8.3  | 7.6 | 7   | 78                 |
| 80                 |      |      |      |      |      |      |      |      | 8.7  | 7.9  | 7.2 | 6.6 | 80                 |
| 82                 |      |      |      |      |      |      |      |      | 8.3  | 7.5  | 6.8 | 6.3 | 82                 |
| 84                 |      |      |      |      |      |      |      |      | 7.9  | 7.2  | 6.5 | 5.9 | 84                 |
| 86                 |      |      |      |      |      |      |      |      | 7.6  | 6.7  | 6.1 | 5.6 | 86                 |
| 88                 |      |      |      |      |      |      |      |      |      | 6.4  | 5.8 | 5.2 | 88                 |
| 90                 |      |      |      |      |      |      |      |      |      | 6.1  | 5.5 | 5   | 90                 |
| 92                 |      |      |      |      |      |      |      |      |      | 5.8  | 5.2 | 4.7 | 92                 |
| 94                 |      |      |      |      |      |      |      |      |      |      | 4.9 | 4.5 | 94                 |
| 96                 |      |      |      |      |      |      |      |      |      |      | 4.7 | 4.2 | 96                 |
| 98                 |      |      |      |      |      |      |      |      |      |      | 4.5 | 3.8 | 98                 |
| 100                |      |      |      |      |      |      |      |      |      |      |     | 3.5 | 100                |
| 102                |      |      |      |      |      |      |      |      |      |      |     | 3.2 | 102                |

# Load Chart - Tower Jib

Unit: t

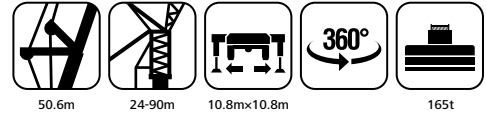

| Working radius (m) | 24   | 30   | 36   | 42   | 48   | 54   | 60   | 66   | 72  | 78  | 84  | 90  | Working radius (m) |
|--------------------|------|------|------|------|------|------|------|------|-----|-----|-----|-----|--------------------|
| 32                 |      |      |      |      |      |      |      |      |     |     |     |     | 32                 |
| 34                 |      |      |      |      |      |      |      |      |     |     |     |     | 34                 |
| 36                 |      |      |      |      |      |      |      |      |     |     |     |     | 36                 |
| 38                 | 28.9 |      |      |      |      |      |      |      |     |     |     |     | 38                 |
| 40                 | 27.3 | 25.5 |      |      |      |      |      |      |     |     |     |     | 40                 |
| 42                 |      | 24.0 |      |      |      |      |      |      |     |     |     |     | 42                 |
| 44                 |      | 22.6 | 21.4 |      |      |      |      |      |     |     |     |     | 44                 |
| 46                 |      | 21.5 | 20.3 |      |      |      |      |      |     |     |     |     | 46                 |
| 48                 |      | 20.3 | 19.1 | 18.3 |      |      |      |      |     |     |     |     | 48                 |
| 50                 |      |      | 18.0 | 17.2 |      |      |      |      |     |     |     |     | 50                 |
| 52                 |      |      | 17.2 | 16.3 | 15.1 |      |      |      |     |     |     |     | 52                 |
| 54                 |      |      | 16.3 | 15.5 | 14.3 |      |      |      |     |     |     |     | 54                 |
| 56                 |      |      |      | 14.6 | 13.5 | 13   |      |      |     |     |     |     | 56                 |
| 58                 |      |      |      | 13.9 | 12.8 | 12.3 |      |      |     |     |     |     | 58                 |
| 60                 |      |      |      | 13.3 | 12.2 | 11.7 | 11   |      |     |     |     |     | 60                 |
| 62                 |      |      |      | 12.7 | 11.6 | 11.1 | 10.4 | 10.9 |     |     |     |     | 62                 |
| 64                 |      |      |      |      | 11   | 10.5 | 9.9  | 10.4 |     |     |     |     | 64                 |
| 66                 |      |      |      |      | 10.5 | 10   | 9.3  | 9.8  | 9.4 |     |     |     | 66                 |
| 68                 |      |      |      |      |      | 9.5  | 8.9  | 9.4  | 8.8 |     |     |     | 68                 |
| 70                 |      |      |      |      |      | 9    | 8.4  | 8.8  | 8.4 | 7.6 |     |     | 70                 |
| 72                 |      |      |      |      |      | 8.6  | 8    | 8.4  | 7.9 | 7.1 |     |     | 72                 |
| 74                 |      |      |      |      |      |      | 7.6  | 8.0  | 7.5 | 6.7 | 6   |     | 74                 |
| 76                 |      |      |      |      |      |      | 7.2  | 7.6  | 7.1 | 6.4 | 5.6 |     | 76                 |
| 78                 |      |      |      |      |      |      | 6.8  | 7.2  | 6.7 | 6.0 | 5.2 | 4.3 | 78                 |
| 80                 |      |      |      |      |      |      | 6.5  | 6.8  | 6.1 | 5.5 | 4.9 | 4.1 | 80                 |
| 82                 |      |      |      |      |      |      | 6.1  | 6.4  | 5.8 | 5.2 | 4.7 | 3.9 | 82                 |
| 84                 |      |      |      |      |      |      |      |      | 5.5 | 5.0 | 4.4 | 3.6 | 84                 |
| 86                 |      |      |      |      |      |      |      |      | 5.1 | 4.7 | 4.2 | 3.4 | 86                 |
| 88                 |      |      |      |      |      |      |      |      | 4.9 | 4.5 | 4   | 3.1 | 88                 |
| 90                 |      |      |      |      |      |      |      |      | 4.7 | 4.3 | 3.8 | 2.8 | 90                 |
| 92                 |      |      |      |      |      |      |      |      |     | 4.1 | 3.6 | 2.5 | 92                 |
| 94                 |      |      |      |      |      |      |      |      |     | 3.9 | 3.3 | 2.1 | 94                 |
| 96                 |      |      |      |      |      |      |      |      |     | 3.7 | 2.9 | 1.8 | 96                 |
| 98                 |      |      |      |      |      |      |      |      |     |     | 2.6 | 1.5 | 98                 |
| 100                |      |      |      |      |      |      |      |      |     |     | 2.3 | 1.2 | 100                |
| 102                |      |      |      |      |      |      |      |      |     |     |     |     | 102                |

# Load Chart - Tower Jib

Unit: t

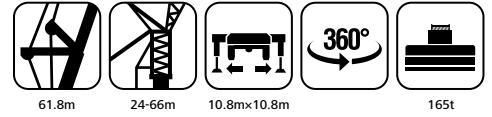

| Working radius (m) | 24   | 30   | 36   | 42   | 48   | 54  | 60  | 66  | Working radius (m) |
|--------------------|------|------|------|------|------|-----|-----|-----|--------------------|
| 42                 | 22.5 |      |      |      |      |     |     |     | 42                 |
| 44                 | 21.3 |      |      |      |      |     |     |     | 44                 |
| 46                 |      | 18.8 |      |      |      |     |     |     | 46                 |
| 48                 |      | 17.7 |      |      |      |     |     |     | 48                 |
| 50                 |      | 16.9 | 15.5 |      |      |     |     |     | 50                 |
| 52                 |      | 15.9 | 14.6 |      |      |     |     |     | 52                 |
| 54                 |      |      | 13.9 | 13.2 |      |     |     |     | 54                 |
| 56                 |      |      | 13.2 | 12.4 |      |     |     |     | 56                 |
| 58                 |      |      | 12.5 | 11.8 | 10.6 |     |     |     | 58                 |
| 60                 |      |      |      | 11.2 | 10.1 |     |     |     | 60                 |
| 62                 |      |      |      | 10.6 | 9.5  | 8.8 |     |     | 62                 |
| 64                 |      |      |      | 10.0 | 9    | 8.4 |     |     | 64                 |
| 66                 |      |      |      | 9.5  | 8.5  | 7.9 | 5.6 | 5.9 | 66                 |
| 68                 |      |      |      |      | 8.1  | 7.5 | 5.3 | 5.6 | 68                 |
| 70                 |      |      |      |      | 7.7  | 7.1 | 5   | 5.3 | 70                 |
| 72                 |      |      |      |      |      | 6.7 | 4.7 | 5.0 | 72                 |
| 74                 |      |      |      |      |      | 6.3 | 4.4 | 4.6 | 74                 |
| 76                 |      |      |      |      |      | 6   | 4.2 | 4.4 | 76                 |
| 78                 |      |      |      |      |      |     | 3.9 | 4.1 | 78                 |
| 80                 |      |      |      |      |      |     | 3.7 | 3.9 | 80                 |
| 82                 |      |      |      |      |      |     | 3.5 | 3.7 | 82                 |
| 84                 |      |      |      |      |      |     | 3.3 | 3.5 | 84                 |
| 86                 |      |      |      |      |      |     | 3.1 | 3.3 | 86                 |

# Load Chart - Tower Jib

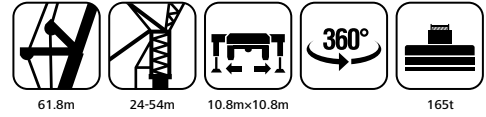

Unit: t

| Working radius (m) | 24   | 30   | 36  | 42  | 48  | 54  | Working radius (m) |
|--------------------|------|------|-----|-----|-----|-----|--------------------|
| 42                 |      |      |     |     |     |     | 42                 |
| 44                 |      |      |     |     |     |     | 44                 |
| 46                 | 16.5 |      |     |     |     |     | 46                 |
| 48                 | 15.6 |      |     |     |     |     | 48                 |
| 50                 |      | 12.4 |     |     |     |     | 50                 |
| 52                 |      | 11.7 |     |     |     |     | 52                 |
| 54                 |      | 11.2 |     |     |     |     | 54                 |
| 56                 |      | 10.6 | 9.1 |     |     |     | 56                 |
| 58                 |      |      | 8.6 |     |     |     | 58                 |
| 60                 |      |      | 8.2 | 6.7 |     |     | 60                 |
| 62                 |      |      | 7.7 | 6.3 |     |     | 62                 |
| 64                 |      |      |     | 5.9 | 4.4 |     | 64                 |
| 66                 |      |      |     | 5.6 | 4.2 |     | 66                 |
| 68                 |      |      |     | 5.2 | 3.9 | 1.7 | 68                 |
| 70                 |      |      |     |     | 3.7 | 1.6 | 70                 |
| 72                 |      |      |     |     | 3.5 | 1.4 | 72                 |
| 74                 |      |      |     |     |     | 1.2 | 74                 |
| 76                 |      |      |     |     |     | 1.1 | 76                 |
| 78                 |      |      |     |     |     |     | 78                 |
| 80                 |      |      |     |     |     |     | 80                 |
| 82                 |      |      |     |     |     |     | 82                 |
| 84                 |      |      |     |     |     |     | 84                 |
| 86                 |      |      |     |     |     |     | 86                 |

# Load Chart - Tower Jib

Unit: t

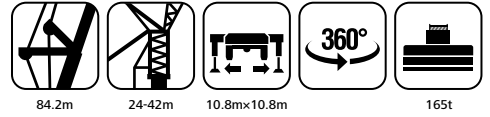

| Working radius (m) | 24  | 30  | 42  | Working radius (m) |
|--------------------|-----|-----|-----|--------------------|
| 42                 |     |     |     | 42                 |
| 44                 |     |     |     | 44                 |
| 46                 |     |     |     | 46                 |
| 48                 |     |     |     | 48                 |
| 50                 |     |     |     | 50                 |
| 52                 | 9.9 |     |     | 52                 |
| 54                 |     |     |     | 54                 |
| 56                 |     | 5.6 |     | 56                 |
| 58                 |     | 5.2 |     | 58                 |
| 60                 |     |     | 2.9 | 60                 |
| 62                 |     |     | 2.8 | 62                 |
| 64                 |     |     | 2.6 | 64                 |
| 66                 |     |     |     | 66                 |
| 68                 |     |     |     | 68                 |
| 70                 |     |     |     | 70                 |
| 72                 |     |     |     | 72                 |
| 74                 |     |     |     | 74                 |
| 76                 |     |     |     | 76                 |
| 78                 |     |     |     | 78                 |
| 80                 |     |     |     | 80                 |
| 82                 |     |     |     | 82                 |
| 84                 |     |     |     | 84                 |
| 86                 |     |     |     | 86                 |



## Sany Automobile Hoisting Machinery Co., Ltd.

No.168, Jinzhou Avenue, Jinzhou Development Zone, Changsha, Hunan, China

Postcode 410600

Tel +86 731-8787 3131 Fax +86 731-8403 1999-196

Service 400 887 8318 Consulting 400 887 9318

Email qzjyx@sany.com.cn

— Authorised Dealer —

### Reminder:

For safe and reliable operation of the diesel engines, please fill Grade IV machines with Grade IV diesel and urea solution conforming to related national standards. Please refer to the operating instructions and related standards for details.

Any change in the technical parameters and configuration due to advancement in technology may occur without prior notice. The machine in the figures may include auxiliary equipment. This brochure is for reference only, and goods in kind shall prevail.

Copyright at Sany Heavy Industry. No part of this catalogue may be copied, recorded or used for any purpose without written approval from Sany Heavy Industry.

© Printed in August 2019 in China

[www.sanyglobal.com](http://www.sanyglobal.com)

