

# SAC1600S

SANY All Terrain Crane  
160 Tons Lifting Capacity



Max. Lifting Capacity: 160 t  
Max. Boom Length: 73 m  
Max. Lifting Height: 101 m

## Excellent performance

- The overall layout is more compact and reasonable, and the design of key structural components is more optimized. The full-extend boom is 73m; the standard jib is 18m, and the optional 2 x 7m standard section can be used up to 32m.
- Innovative five-axle all-terrain chassis design, hydro-pneumatic suspension, all-wheel steering, chassis performance is more reliable and ground clearance is better.
- The self-developed dual-pumping/split technology can realize both efficiency and controllability.
- It adopts single-engine mechanical transmission, independent main oil pump and hydraulic fuel tank system. The reliability is high, and there is no risk of escalating emissions.

## Excellent quality

- It adopts advanced single-cylinder pin telescopic arm technology, the cylinder arm pin interlocks with mechanical, electrical and hydraulic triple protection, therefore the reliability is higher.
- It adopts closed-type rotary buffer system for smoother start-up and braking, and the micro-motion is more excellent.
- It adopts self-developed dual-pump combined/split technology which makes the single-action double-pump combined flow more efficient, and the combined action double-pump split flow controllability is better.
- It adopts international advanced distributed integrated data communication network, the data volume is large, the speed is fast, and the stability is high.
- Through the human-computer interaction interface, customers can set their own vehicle controllability according to their personal operating habits and different usage conditions to meet their needs. With hydro-pneumatic suspension technology, it can adapt to all kinds of bad road conditions. With better ground clearance, driving can be more comfortable.
- The streamlined full-width cab and variable-position panoramic sunroof-style operator room offer a wider field of view and more comfortable operation.
- The extensive application of advanced manufacturing technology ensures that every process is refined and effectively guarantees the excellent performance of the product.

## Energy saving

- With electric proportional pump, displacement and speed binning control can save 20% energy.
- With dual-pump/split intelligent speed control technology, it can meet the needs of various action combinations which can save energy.



## Safety and reliability

- It is equipped with an anti-rollover warning system to provide early warning through sound and light to ensure the safety operation of the vehicle.
- It is equipped with a voice alarm system to provide voice prompts for various actions to prevent misoperations and prompts and alarms to surrounding personnel, ensuring the safety of vehicle operation and personnel.
- It is equipped with high-precision, high-stability, high-intelligence torque limiter system protects the lifting operation in all aspects.
- It is equipped with rich sensor components, timely feedback of data information, real-time monitoring, to keep abreast of the working state of the vehicle.

## GCP system

- It adopts equipment remote monitoring and management system with powerful equipment operating conditions and operating parameter collection functions, which can implement remote fault diagnosis and management.
- Customers can master the operation of the equipment, inquire and order accessories without leaving home.



## Overall Dimensions

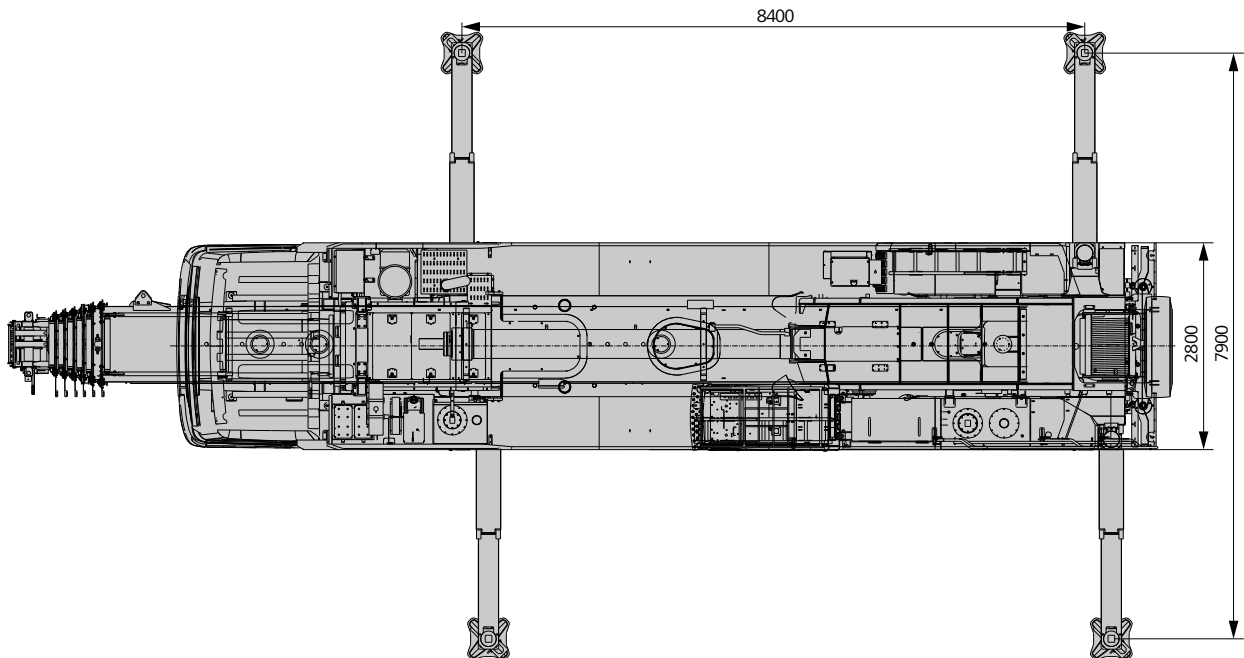
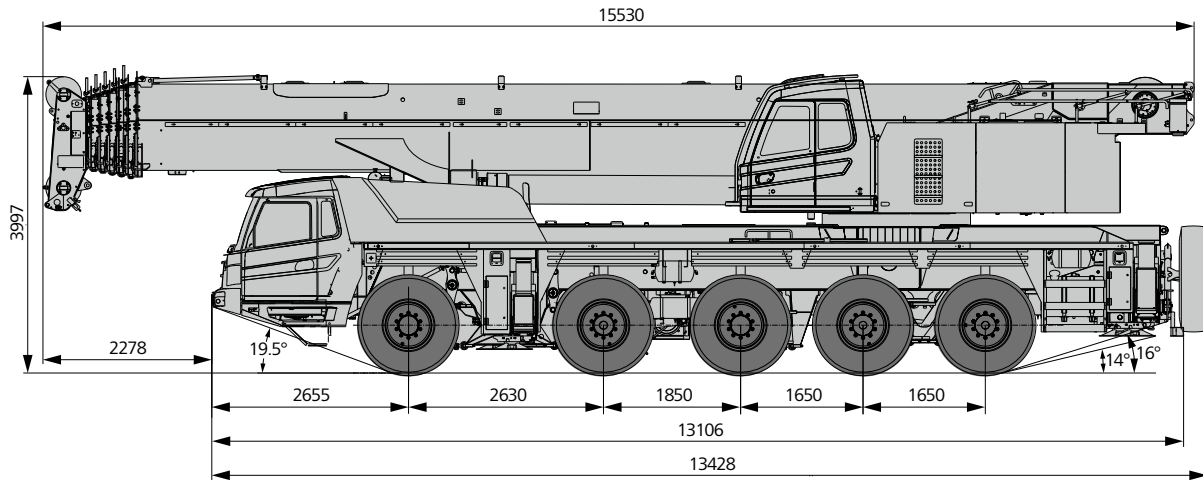

## Technical Parameters

Type	Item	Unit	Parameter	
Dimension	Full length	mm	15530	
	Full width	mm	2800	
	Full height	mm	4000	
	Axle base	No.1 and No.2 axle base	mm	2630
		No.2 and No.3 axle base	mm	1850
No.3 and No.4 axle base		mm	1650	
No.4 and No.5 axle base		mm	1650	
Weight	Crane total weight	kg	57000 (hook, jib, auxiliary winch, spare tire bracket not included)	
	Load	Load on No.1, 2, 3 axles	kg	34400
		Load on No. 4,5 axles	kg	22600
Power	Engine power	kw/rpm	360/1800	
	Engine torque	Nm/rpm	2200/1300	
Driving parameters	Max driving speed	km/h	80	
	Steering radius	Min steering radius of tires	m	8.5
	Wheel mode		-	10x6x10
	Min ground clearance		mm	285
	Approach angle		°	19.5
	Departure angle		°	16
	Max gradeability		%	46
	Fuel consumption per 100 km		L	67
Main performance parameters	Temperature range	°C	-20 ~ +40	
	Min rated radius	m	3	
	Slewing platform tail radius	m	4.86	
	Number of boom sections	-	7	
	Boom shape	-	U	
	Max lifting torque	Basic boom	kN·m	5174
		Full-extend boom	kN·m	2058
	Boom length	Basic boom	m	13.6
		Full-extend boom	m	73
	Outrigger span (vertical X horizontal)	m	8.4x7.9	
Jib angle	°	0、15、30		
Working speed	Max lifting speed of single rope of main winch(unloaded)	m/min	130	
	Max lifting speed of single rope of auxiliary winch (unloaded)	m/min	130	
	Boom full extend and retract time	s	600	
	Boom full rise and lower time	s	55	
	Slewing speed	r/min	1.5	
Air conditioner	Superstructure air conditioner	-	Heating, cooling	
	Carrier air conditioner	-	Heating, cooling	

## Technical Parameters



### Axle Load

Axle	1	2	3	4	5	Overall mass
Axle load / t	<12t	<12t	<12t	<12t	<12t	57
Remarks	-					



### Hook

Rated load/t	Number of pulleys	Rope rate	Hook weight / kg
80	3	7	695
12.5	0	1	270



### Main Working Parameters

Project	Parameter	Rope diameter / length	Max single line pull
Main winch	-	22/280	10.5
Auxiliary winch	-	22/210	10.5
Slewing		0~1.5	
Boom rise and lower		55/105S	
Boom extend and retract		600S	
Vertical outrigger	Retract	30s	
	Extend	35s	
Horizontal outrigger	Retract	30s	
	Extend	25s	

## Crane Introduction

Temperature: -20°C ~ 40°C

Road conditions: able to work in desert, oil fields, gobi and other poor road conditions

### Cab

- 0°~ 20°variable angle, with corrosion-resistant steel plate, full-cover softened interior, panoramic sunroof, adjustable seat and other humanized design, the operation is more comfortable and relaxed; with torque limiter display, it realizes the organic combination of the main control console and the operation display system, so that all the working condition data of the lifting operation can be seen at a glance.

### Frame

- The frame is a box-shaped structure welded by high-strength steel plates with strong bearing capacity.

### Drive engine

- OM460LA.E3A 360kW Euro III Benz six-cylinder, water-cooled, supercharged intercooler, diesel engine.
- Rated power:360kw/1800rpm
- Environmentally friendly: Emissions meet Euro III standards.
- Fuel tank capacity: 600L.

### Gearbox

- Germany ZF automatic transmission, the transmission has 12 forward gears, 2 reverse gears, the speed ratio range is large, which can meet the low-speed field climbing and high-speed driving.

### Axle

- Germany Kessler handle, Germany Kessler transfer case. Full handle steering, 2, 4, 5 handle drive, 2, 4 and 5 for planetary drive with inter-wheel differential lock. The 1 and 2 bridges adopt the hydraulic power steering system with linkage feedback. The 3, 4 and 5 bridges adopt electro-hydraulic control steering, which can be used for speed control and optional special steering mode. The steering is light and flexible.

### Steering / drive

- 10x6x10.

### Suspension system

- All axle suspension devices are height-adjustable hydraulic suspension devices with hydraulic lockout. The suspension height can be adjusted to 190 and 100mm. It can be used in all kinds of harsh working conditions and roads to ensure the smoothness and stability of the vehicle and comfortable driving.

### Tire

- Techking, 10X14.00R25,meridian vacuum tire.

### Braking system

- Parking brake: actuated by the accumulator on the second to fifth bridges.
- Service Brake: all wheels use air servo brakes, dual-circuit brake system, and all wheels are equipped with disc brakes.
- Auxiliary Brake: the engine is equipped with engine brake, hydraulic retarder brake and exhaust brake to reduce the crane in advance, which can reduce the wear of the brake components and save the use cost.

### Steering system

- It is equipped with servo power steering, dual-circuit system hydraulic steering. The 3, 4 and 5 bridges adopt electro-hydraulic steering control, and the steering strategy is adjusted according to the speed. The 3 bridges do not turn from 30km/h, and the 4th and 5th bridges do not turn from 60km/h.
- There are six types of steering modes: 1. road driving mode (default mode); 2. all-wheel steering mode; 3. crab mode; 4. unbiased steering mode; 5. independent rear axle steering mode; 6. rear axle locking steering mode.

### Outrigger

- It adopts H-shaped telescopic legs, 4 points support, longitudinal and span distance 8.4X7.9, and full hydraulic horizontal vertical leg cylinders expand and contract with automatic leveling function.

### Electrical equipment

- Modern data bus system, 24V DC power supply, 2 sets of battery packs, 180AH per group. It can cut off the power supply of carrier.
- The chassis adopts CAN bus system; multi-functional centralized display system; the power consumption is small with 5w at maximum; four function keys are provided in the user interface; the display uses LCD liquid crystal and the contrast can be adjusted.

## Crane Introduction

### Operating cab

- Sany develops ergonomic design, sliding door, safety glass, corrosion-resistant steel plate, softened interior, large interior space, panoramic sunroof, adjustable seat and other humanized design, equipped with air conditioner, electric wiper, which makes operation more comfortable and relaxed; with torque limiter display, it realizes the organic combination of the main control console and the operation display system, so that all the working condition data of the lifting operation can be seen at a glance.

### Boom system

- Main boom: seven-section arm, basic arm 13.6m, full-stretch arm 73m, main arm full extension height 73.5m, which is made of high-strength welded structural steel, U-shaped section.
- Jib: standard auxiliary arm 18m, optional (2 x 7m) up to 32m, maximum lifting height 100.5m. 0°/15°/30° mechanical variable amplitude.
- Telescopic mechanism: it adopts single-cylinder bolt telescopic mode, with full extension and full reduction time of only 660S. The telescopic mechanism is simple, efficient, safe and reliable.

### Lifting mechanism

- The main hoisting adopts electric proportional variable motor, and the hoisting is fine and smooth. The diameter of the main and auxiliary hoisting ropes is 22mm, and the length is 280m and 210m respectively.

### Luffing mechanism

- It is more energy-efficient with self-weight variable amplitude. With single-cylinder, the front hinge is arranged, the amplitude is more labor-saving and the force of the boom is improved; the electric proportional control balance valve is adopted. Amplitude angle:  $-0.5^{\circ} \sim 81.5^{\circ}$ .

### Control system

- Electronic control (PLC control) of the crane truck through the SYMC torque limiter system independently developed by Sany; adjust the movement of the crane by adjusting the hydraulic pump. Speed is adjusted by adjusting the speed of the engine.

### Slewing system

- 360° slewing, maximum slewing speed 1.5r/min; 1 closed proportional variable displacement pump, 2 axial quantitative plunger hydraulic motors. The electric proportional closed hydraulic circuit and the electric proportional pedal can realize emergency braking.

### Slewing platform

- Sany independent design, the structure is more optimized, which is made of fine grain high strength steel.

### Hydraulic system

- With the use of high-quality main oil pump, rotary pump, main valve, hoisting motor, balance and other key hydraulic components, it ensures that the hydraulic system is stable and reliable; with accurate parameter matching, the operational performance is superior; with electric proportional variable displacement piston pump to adjust the displacement of the oil pump in real time through the change of the opening degree of the electric control handle, it realizes high-precision flow control, and there is no energy loss during operation; with self-developed double-pump/split main valve, higher efficiency of single-action and double-pump combined flow can be achieved, and the combined action and double-pump split flow control can be better.
- With the self-weight drop compensation hydraulic system, the amplitude of the movement and the stability is superior.
- The main arm telescopic system uses a single cylinder latch telescopic system.
- The rotary system is a closed system. The flow rate and direction are changed by adjusting the angle of the variable pump swash plate, and the micro-motion is superior and the rotation is stable.

### Safety device

- Torque limiter: using the analytical mechanics method, a torque limiter calculation system based on the hoisting mechanics model is built. The rated hoisting accuracy is  $\pm 5\%$  by online no-load calibration, and the hoisting operation is fully protected. When overloading, the system automatic alarm prompts provide security for maneuvering operations.
- The hydraulic system is equipped with components such as hydraulic balance valve, relief valve and two-way hydraulic lock to achieve stable and reliable hydraulic system.
- The main and auxiliary hoists are equipped with a three-ring protector to prevent the wire rope from being over-discharged.
- A height limiter is arranged at the arm ends of the main and auxiliary arms to prevent the wire rope from being over-wrapped.
- An anemometer is installed at the arm end to detect whether the high-altitude wind speed exceeds the allowable range of operation.

### Counterweight

- The removable counterweight is 50.5t. The crane can drive with 14.5t counterweight.



# Boom Operating Range

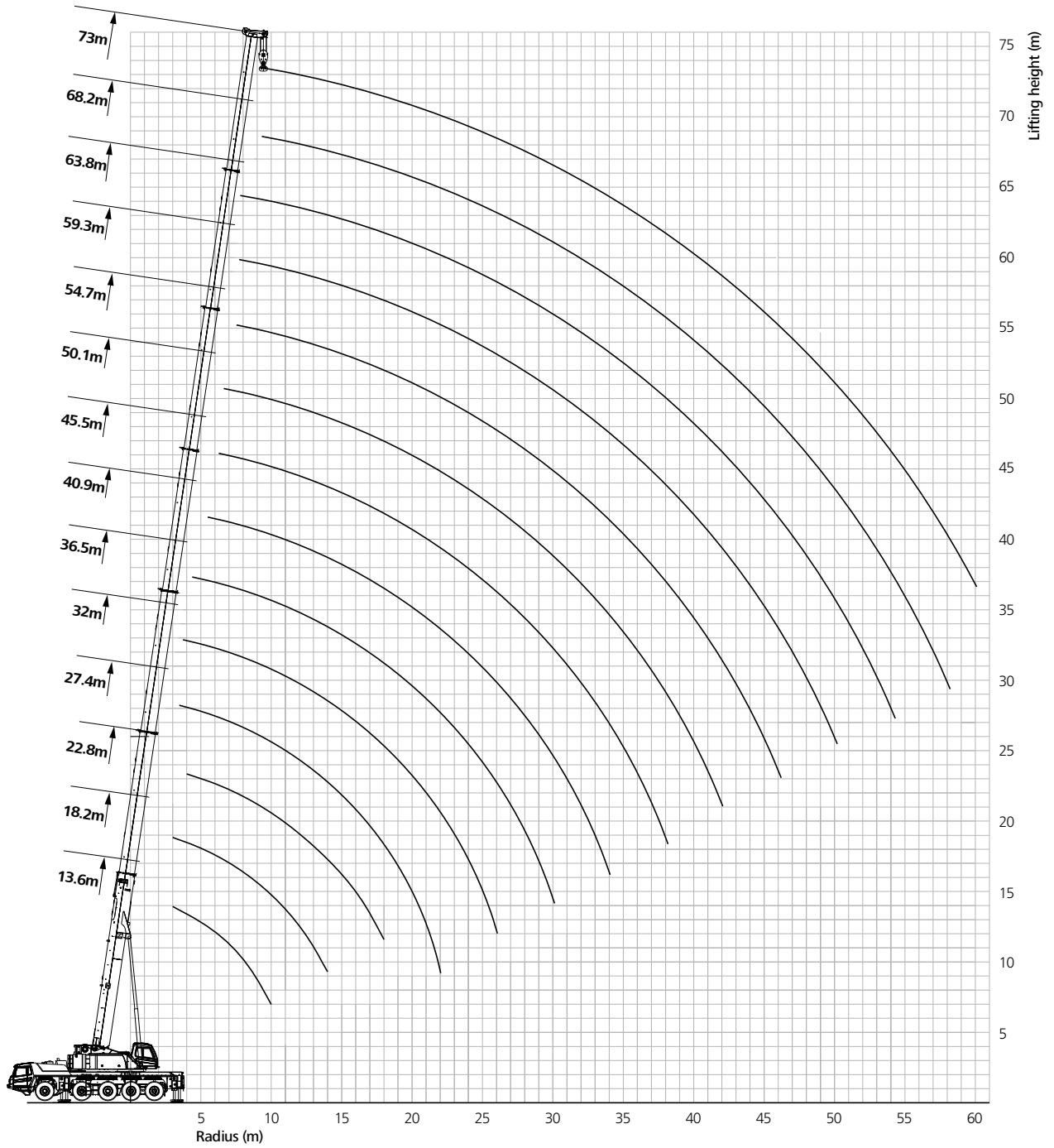

# Load Chart - Telescopic Boom

Unit: t



Radius (m)	13.6	18.2	18.2	22.8	22.8	27.4	27.4	32.0	32.0	32.0	Radius (m)
3	160*										3
3	130	115	105								3
3.5	126	110	100	95	95						3.5
4	117	106	94	95	95						4
4.5	109	101	88.5	95	90						4.5
5	100	96	85	91	87	85	57.5				5
6	87	85	78	85	82	78	51.5	72	71	57.5	6
7	75	75	71	76	73	70	46.5	72	64.5	53	7
8	66	66	64	66	65	63	42	64.5	58.5	48	8
9	58	60	59	60	58	57	39	58.5	54	44.5	9
10	49	55	53	55	52	52	36	53.5	49	41	10
12		43	43.5	42.5	45	43.5	31	44	42	35.5	12
14		33	34	33.3	35.5	34	28	34.5	36	30.5	14
16				26.6	29	27.2	25	28	29.5	27.5	16
18				22	24	22.5	22	23.2	24.5	24.5	18
20						19	19.5	19.5	21	22	20
22						16.2	18	16.7	18	19.5	22
24								14.5	15.5	17	24
26								12.5	13.6	15	26
28											28
30											30
32											32
34											34
36											36
38											38
40											40
42											42
44											44
46											46
48											48
50											50
52											52
54											54
56											56
58											58
60											60
62											62
Rate	12	11	11	9	9	8	8	7	7	7	Rate

\* over rear

# Load Chart - Telescopic Boom

Unit: t



Radius (m)	36.5	36.5	36.5	40.9	40.9	40.9	45.5	45.5	45.5	50.1	50.1	50.1	Radius (m)
3													3
3.5													3.5
4													4
4.5													4.5
5													5
6													6
7	62	55	55										7
8	62	52	52	51.5	42	34							8
9	57	48	48	49	39	31.5	35	28	35.5				9
10	53	44	44	46	37	29.5	33	26.5	33	28.5	21	25	10
12	45	39	38.5	41	32	26	29.5	24	29	25.5	19	22.5	12
14	35.5	34	34	36	28	23	26.5	21.5	25.5	23	17	20	14
16	29	30	28.5	29.5	25	20.5	23.5	19.5	23	20.5	15.5	18	16
18	24	25	23.5	24.5	22.2	18.5	21	18	20.5	18.5	14	16.5	18
20	20.5	21.5	20	21	19.5	16.5	19	16.2	18.5	17	13	15	20
22	17.5	18.6	17.2	18	16.8	15	17.2	15	16.5	15.2	12	14	22
24	15	16.3	15	16	14.5	13.5	15	14	14.5	14	11	12.5	24
26	13.2	14.4	13	14	12.5	12.5	13.2	13	12.6	12.5	10	11.5	26
28	11.5	12.7	11.5	12.2	11	12	11.5	12	11	11.5	9.5	10.5	28
30	10.2	11.5	10	11	9.5	11	10.2	11.2	9.5	10	8.7	9.8	30
32				9.5	8.2	10.2	9	10.2	8.5	9	8.2	9	32
34				8.5	7.2	9.5	8	9.2	7.4	8	7.5	8.3	34
36				0	0	0	7	8.2	6.5	7	7.2	7.5	36
38							6	7.5	5.6	6.2	6.6	7	38
40										5.5	6.3	6.3	40
42										4.6	6	5.5	42
44													44
46													46
48													48
50													50
52													52
54													54
56													56
58													58
60													60
62													62
Rate	6	6	6	5	5	5	4	4	4	3	3	3	Rate

# Load Chart - Telescopic Boom



Unit: t

Radius (m)	54.7	54.7	54.7	59.3	59.3	59.3	63.8	63.8	68.2	73.0	Radius (m)
3											3
3.5											3.5
4											4
4.5											4.5
5											5
6											6
7											7
8											8
9											9
10											10
12	22.5	17	19								12
14	20	15.5	17	17	17	14	15	13.5			14
16	18	14.2	15.5	16	15.5	13	14	12.5	12	10	16
18	16.5	13	14	14.5	14.2	12	13	12	11.2	9.6	18
20	15	12	13	13.2	13.2	11.2	12	11	10.5	9.2	20
22	14	11	11.6	12.2	12.2	10.5	11.2	10.2	9.8	8.7	22
24	12.5	10	10.7	11.2	11	10	10.3	9.5	9.2	8.3	24
26	11.5	9.5	10	10.5	10.3	9	9.5	9	8.6	7.8	26
28	11	9	9.1	9.5	9.5	8.5	9	8.5	8.2	7.5	28
30	10	8	8.5	9	8.7	8	8.2	8	7.7	6.8	30
32	9	7.5	7.7	8.2	8	7.5	8	7.5	7.1	6.5	32
34	8	7	7.3	7.5	7.5	7	7.3	7	6.7	6	34
36	7	6.5	6.7	7	7	6.5	6.6	6.5	6.3	5.6	36
38	6	6.1	6.3	6.3	6.2	6	6.2	6	6	5.2	38
40	5.3	5.7	6	5.6	5.5	5.6	5.7	5.6	5.5	4.8	40
42	4.5	5.5	5.5	5	5	5.3	5.3	5.2	5.2	4.5	42
44	4	5	5	4.5	4.4	5	4.7	5	4.8	4.2	44
46	3.5	4.6	4.5	4	3.8	4.6	4.2	4.6	4.5	3.9	46
48				3.5	3.3	4.3	3.7	4.3	4	3.6	48
50				3	2.8	4	3.3	4	3.5	3.3	50
52							2.8	3.6	3	3	52
54							2.4	3.2	2.6	2.7	54
56									2.3	2.3	56
58									2	2	58
60										1.7	60
62										1.3	62
Rate	3	3	3	2	2	2	2	2	2	2	Rate

# Jib Operating Range

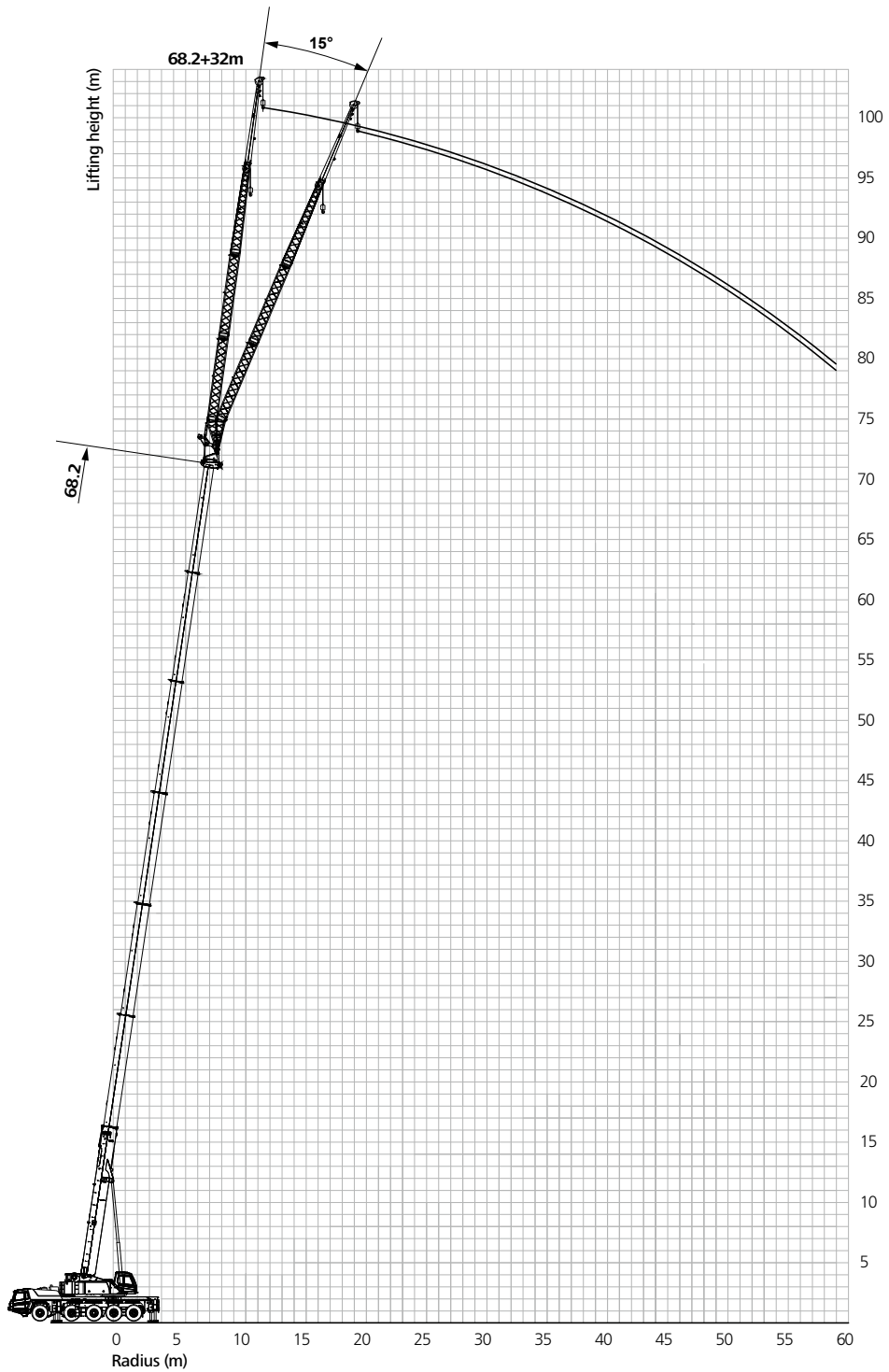

# Load Chart - Fixed Jib

Unit: t

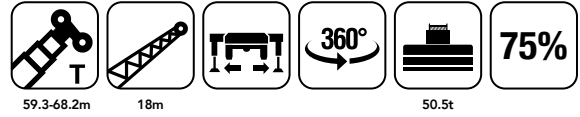

Radius (m)	59.3			63.8			68.2			Radius (m)
	0°	15°	30°	0°	15°	30°	0°	15°	30°	
20	4.5			4.2			3.6			20
22	4.3	3.5		4	3.2		3.5	3.2		22
24	4	3.3		3.9	3.1		3.4	3.1		24
26	3.8	3.3	2.5	3.7	3.1	2.5	3.3	3.1	2.5	26
28	3.7	3.2	2.5	3.6	3.1	2.4	3.2	3	2.4	28
30	3.6	3.2	2.4	3.5	3.1	2.3	3.1	3	2.3	30
32	3.5	3.1	2.3	3.4	3.1	2.3	3	2.8	2.3	32
34	3.4	3.1	2.3	3.3	3	2.2	2.8	2.6	2.2	34
36	3.3	3.1	2.2	3.2	3	2.2	2.6	2.5	2.2	36
38	3.2	3	2.2	3.1	3	2.1	2.5	2.4	2.1	38
40	3.1	3	2.1	3	2.9	2.1	2.5	2.3	2.1	40
42	3	3	2.1	2.8	2.8	2	2.2	2.1	2	42
44	2.9	2.9	2	2.6	2.6	2	2	2	1.9	44
46	2.6	2.7	2	2.4	2.4	1.9	1.9	1.9	1.8	46
48	2.4	2.5	2	2.2	2.2	1.9	1.8	1.8	1.7	48
50	2.1	2.3	1.9	2	2.1	1.8	1.7	1.8	1.6	50
52	2	2	1.9	1.7	1.9	1.7	1.6	1.7	1.5	52
54	1.7	1.9	1.8	1.6	1.6	1.6	1.5	1.6	1.4	54
56	1.4	1.6	1.7	1.3	1.5	1.5	1.3	1.5	1.3	56
58	1.1	1.3	1.5	1.1	1.3	1.4	1.1	1.3	1.2	58
60		1.1	1.2		1	1.2	1	1	1.1	60
62			1			1			1	62
II	92	92	92	92	92	92	92	92	92	II
III	92	92	92	92	92	92	92	92	92	III
IV	92	92	92	92	92	92	92	92	92	IV
V	92	92	92	92	92	92	92	92	92	V
VI	46	46	46	92	92	92	92	92	92	VI
VII	46	46	46	46	46	46	92	92	92	VII

## Load Chart - Fixed Jib

Unit: t



Radius (m)	59.3			63.8			68.2			Radius (m)
	0°	15°	30°	0°	15°	30°	0°	15°	30°	
18	2		2		2		3.6			18
20	2		2		2		3.5	3.2		20
22	1.9		2		1.8		3.4	3.1		22
24	1.8		1.9		1.8		3.3	3.1	2.5	24
26	1.8	1.8	1.8	1.7	1.7	1.6	3.2	3	2.4	26
28	1.8	1.8	1.8	1.6	1.7	1.6	3.1	3	2.3	28
30	1.7	1.8	1.7	1.5	1.6	1.5	3	2.8	2.3	30
32	1.5	1.8	1.5	1.5	1.6	1.5	2.8	2.6	2.2	32
34	1.5	1.7	1.5	1.4	1.6	1.5	2.6	2.5	2.2	34
36	1.5	1.5	1.5	1.4	1.5	1.4	2.5	2.4	2.1	36
38	1.5	1.5	1.4	1.4	1.4	1.4	2.5	2.3	2.1	38
40	1.4	1.5	1.4	1.4	1.3	1.4	2.2	2.1	2	40
42	1.3	1.4	1.4	1.3	1.2	1.3	2	2	1.9	42
44	1.3	1.4	1.3	1.3	1.2	1.3	1.9	1.9	1.8	44
46	1.3	1.3	1.2	1.2	1.2	1.2	1.8	1.8	1.7	46
48	1.2	1.2	1.2	1.2	1.2	1.2	1.7	1.8	1.6	48
50	1.2	1.2	1.1	1.1	1.1	1.2	1.6	1.7	1.5	50
52	1.2	1.2	1.1	1.1	1.1	1.1	1.5	1.6	1.4	52
54	1.1	1.1	1.1	1.1	1.1	1.1	1.3	1.5	1.3	54
56	1	1.1	1	1.1	1	1.1	1.1	1.3	1.2	56
58		1		1	1	1	1	1	1.1	58
60						1			1	60
II	92	92	92	92	92	92	92	92	92	II
III	92	92	92	92	92	92	92	92	92	III
IV	92	92	92	92	92	92	92	92	92	IV
V	92	92	92	92	92	92	92	92	92	V
VI	46	46	46	92	92	92	92	92	92	VI
VII	46	46	46	46	46	46	92	92	92	VII



## Sany Automobile Hoisting Machinery Co., Ltd.

No.168, Jinzhou Avenue, Jinzhou Development Zone, Changsha, Hunan, China

Postcode: 410600

Service: 0086-400 6098 318 Consulting: 400 8879 318

Email: [crd@sany.com.cn](mailto:crd@sany.com.cn)

— Authorised Dealer —

### Reminder:

For safe and reliable operation of the diesel engines, please fill Grade IV machines with Grade IV diesel and urea solution conforming to related national standards. Please refer to the operating instructions and related standards for details.

Any change in the technical parameters and configuration due to advancement in technology may occur without prior notice. The machine in the figures may include auxiliary equipment. This brochure is for reference only, and goods in kind shall prevail.

Copyright at Sany Heavy Industry. No part of this catalogue may be copied, recorded or used for any purpose without written approval from Sany Heavy Industry.

© Printed in November 2019 in China

[www.sanyglobal.com](http://www.sanyglobal.com)

