

STC300H

STC300H TRUCK CRANE
30 TONS LIFTING CAPACITY

Quality Changes the World

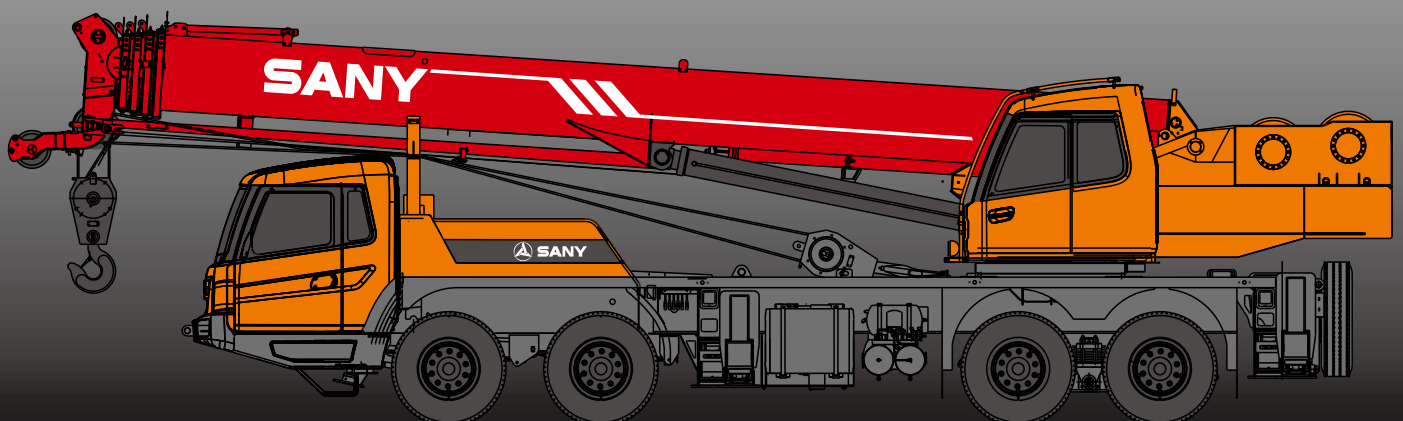

SANY

■ SANY Automobile Hoisting Machinery is one of the core business unit of Sany Heavy Industry, mainly engaged in the research and development of high end, mid to large tonnage crane series, including mobile crane, crawler crane, tower crane and loader crane. It has two industrial parks in Ningxiang and Huzhou, since entering the market, the products of Sany Automobile Hoisting Machinery have received worldwide recognition with advanced technology, lean manufacturing, high reliability and excellent service.



SANY TRUCK CRANE

CONTENT

- 04 Icon
- 05 Selling Points
- 06 Introduction
- 09 Dimension
- 10 Technical Parameter
- 11 Operation Condition
- 12 Load Chart
- 14 Wheel Crane Family Map



Cab



Carrier frame



Suspension system



Hydraulic system



Outriggers



Telescopic boom



Control system



Engine



Lattice jibs



Telescopic system



Transmission system



Superlift devices



Luffing system



Drive/Steer



Luffing lattice jib



Slewing



Axles



winch mechanism:



Counterweight



Tyres



Safety system



Brakes system



Hoist system



Electrical system



Excellent and stable chassis performance / chassis system

Double-axle drive is used, providing good trafficability and comfortableness under complex road condition with reliable traveling performance.

Engine has the multimode power output function, which reduces power consumption.

The use of tipping over early-warning technology provides high stability and safety of the overall operation.



Highly efficient, stable, energy-saving and adjustable hydraulic system

Hydraulic system load feedback and variable piston pump are applied to provide strong lifting capacity and good micro-mobility. Unique steering buffer design is applied to ensure stable braking operation.



Ultra long, super strong and highly sensitive load lifting capacity

Five-section boom of high strength steel structure and optimized U-shaped cross section reduces weight significantly with higher safety rates. Jib mounting angles are 0°, 17°, and 30° which ensures fast and convenient change-over between different operating conditions so as to improving working efficiency of the machine.





Safe, stable, advanced, and intelligent electric control system

Self-developed controller SYMC specially for engineering machinery is configured. The adoption of CAN-bus full-digital network control technology ensures stable control signal, simple harness, and high reliability. Timely feedback of data information can achieve the monitoring of the overall working status in real time. The load moment limiter equipped with the comprehensive intelligent protection system is used with accuracy within 3% to provide a comprehensive logic and interlock control, thus ensuring more safe and reliable operation.

Superstructure

-  **Cab**
- It is made of anti-corrosion steel plate with ergonomic design such as full-coverage soften interior, panoramic sunroof and adjustable seats etc., and humanized design providing more comfortable and relaxing operation experience. The display of load moment limiter integrates main console and operation display system, which clearly show the data of all operating superstructure conditions for lifting operation.

-  **Hydraulic system**
- High-quality key hydraulic components such as main oil pump, rotary pump, main valve, winch motor, and balancing parts etc. are adopted to achieve stable and reliable operation of the hydraulic system. Superior operation performance is guaranteed by accurate parameter matching.
 - Main valve has flow compensation, load feedback control function, enabling stable and convenient control of single action and combined action under different operation conditions.
 - Winch adopts the electronically controlled variable motor to ensure high operation efficiency. Max. single line speeds of main and auxiliary winches is above 130m/min.
 - Slewing system is equipped with the integrated slewing buffer valve with free slipping function to ensure more stable starting and control of the slewing operation and excellent micro-mobility.
 - Hydraulic oil tank capacity: 520L.

-  **Control system**
- CAN-bus instrument: CAN-bus instrument with a combined intelligent control electrical system is used for easy reading of the traveling parameters at any time. The engine fault warning function is applied to ensure convenient and fast troubleshooting.
 - With fully security protection system, main and auxiliary winches are equipped with over-roll out limiter and height limiters to prevent over-rolling out and over-hoisting of steel rope, including tip-over and limit angle protection.
 - Load moment limiter: The adoption of high intelligent load moment limiter system can comprehensively protect lifting operation, ensuring accurate, stable and comfort operation.
 - The fault diagnosis system can detect superstructure electricity, hydraulic action, chassis (for major safety failure), engine and gearbox for fault to ensure reliable operation of the crane.

-  **Luffing system**
- Power lowering system provides uniformity and safety, smooth lowering speed.
 - Luffing angle: $-2^{\circ} \sim 80^{\circ}$.

-  **Telescopic system**
- Five-section boom is applied with basic boom length of 10.5m, full-extended boom length of 39.5m, jib length of 8.5m and lifting height of fully extended boom length of 40m respectively. Max. lifting height is 48m including jib. It is made of fine grain high-strength steel with U-shaped cross section and with telescopic operation controlled independent by dual-cylinder rope.

-  **Slewing system**
- 360° rotation can be achieved with Max. slewing speed of 2.5r/min, providing stable and reliable operation of the system. Variable plunger hydraulic motor, 3 level planetary reducer, spring disc braking lock and single-row ball slewing ring are adopted for strong bearing capacity, good stability, high safety, and good micro-mobility.

Superstructure

-  **Hoisting system**
- Highly efficient and energy-saving variable speed adjustment can be achieved by plunger motor. With perfect combination of winch balance valve and unique anti-slip technology, heavy load can lift and lower smoothly.
 - Closed winch brake and winch balance valve effectively prevent imbalance of the hook.
 - One main hook: 360kg, one auxiliary hook: 100kg. Wire rope of main winch: left-handed wire rope: 16-35W \times 7-1960USZ 200m. Wire rope of auxiliary winch: left-handed wire rope: 16-35W \times 7-1960USZ 105m.

-  **Safety system**
- Load moment limiter: Load moment limiter calculation system based on lifting load mechanical model is established using an analytical mechanics method with rated lifting accuracy up to $\pm 3\%$ through on-line non-load calibration, providing full protection to lifting operation. In case of overload operation, system will automatically issue an alarm to provide safety protection for manipulation.
 - Hydraulic system is configured with the balance valve, overflow valve, and two-way hydraulic lock etc. components, thus achieving the stable and reliable operation of the hydraulic system.
 - Main and auxiliary winches are equipped with over roll-out limiter to prevent over rolling-out of wire rope.
 - Boom and jib ends are equipped with height limiters respectively to prevent over-hoisting of wire rope.
 - Boom head is equipped with anemometer, press sensor, to indicate the working condition of whole crane in real-time, giving an alarm and cutting off the dangerous action automatically.

-  **Counterweight**
- Counterweight is 4500kg, no flexible counterweight.

Chassis







-  **Cab**
- Cab is made of new steel structure self-developed by SANY, featuring excellent shock absorption and tightness, which is configured with swing-out doors at both sides, pneumatically suspended driver's seat and passenger seat, adjustable steering wheel, large rearview mirror, comfort driver chair having a headrest, anti-fog fan, air conditioner, stereo radio, and complete control instruments and meters, providing more comfortable, safe and humanized operation experience.

-  **Carrier frame**
- Designed and manufactured by SANY, anti-torsion box structure is welded by fine-grain high-strength steel plate to provide strong load bearing capacity.

-  **Axles**
- Axles 3 and 4 are drive axles and axles 1 and 2 are steering axles, axle and wheel differentials are installed in axle 3 and wheel differential is installed in axle 4. The use of welding process for axle housing provides stronger load bearing capacity.

-  **Engine**
- Type: Inline six-cylinder, water cooled, supercharged and inter-cooling diesel engine
 - Rated power: 213kw/2100r/min
 - Environment-protection: Emission complies with EuroIII standard
 - Capacity of fuel tank: 300L

Chassis

-  **Transmission system**
- Gearbox: Manual gearbox is adopted with 9-gear and large speed ratio range applied, which meets the requirements of low gradability speed and high traveling speed.
 - Transmission shaft: With optimized arrangement of the transmission shaft, the transmission is stable and reliable. For most optimized transmission, face-tooth coupling transmission shaft is used with large transmission torque.
-  **Brakes system**
- Brakes system includes traveling brake, parking brake, emergency brake, and auxiliary brake.
 - Traveling brake: All wheels use the air servo brakes and dual-circuit brake system and are equipped with disk brakes.
 - Parking brake: Force driven by accumulator is applied on the second to fourth axle. For emergency brake, accumulator is used not only for cutting-off brake but also for emergency brake.
 - Auxiliary brake consists of engine brake and exhaust brake. Engine is equipped with dual brake, transmission is equipped with hydrodynamic retarder brake, and forth axle is equipped with eddy current retarder brake ensure safe and reliable traveling.
-  **Suspension system**
- All axles adopt the plate spring suspension systems with plate spring passed 100,000 fatigue tests and with optimization of performance parameters of the front and rear plate springs applied to ensure strength and provide comfort ridding.
-  **Steering system**
- Hydraulic power mechanical steering systems are applied for axles 1 and 2 with unloading valve installed in the steering gear.
-  **Outriggers**
- Four /Five-point supporting of the H-shaped outriggers ensures easy operation and strong stability with Max. span up to 5.3m×6.2m. They are made of fine-grain high-strength steel sheet with horizontal single-cylinder rope line telescoping for first and second outriggers. Vertical cylinder of outrigger adopts bi-directional hydraulic locks to improve safety.
-  **Tyres**
- 11.00R20-18PR
-  **Electrical system**
- With 2*12V maintenance-free batteries, the crane power can be cut off manually via a mechanical master power switch. The use of CAN-bus control system can achieve information interaction between superstructure and undercarriage.

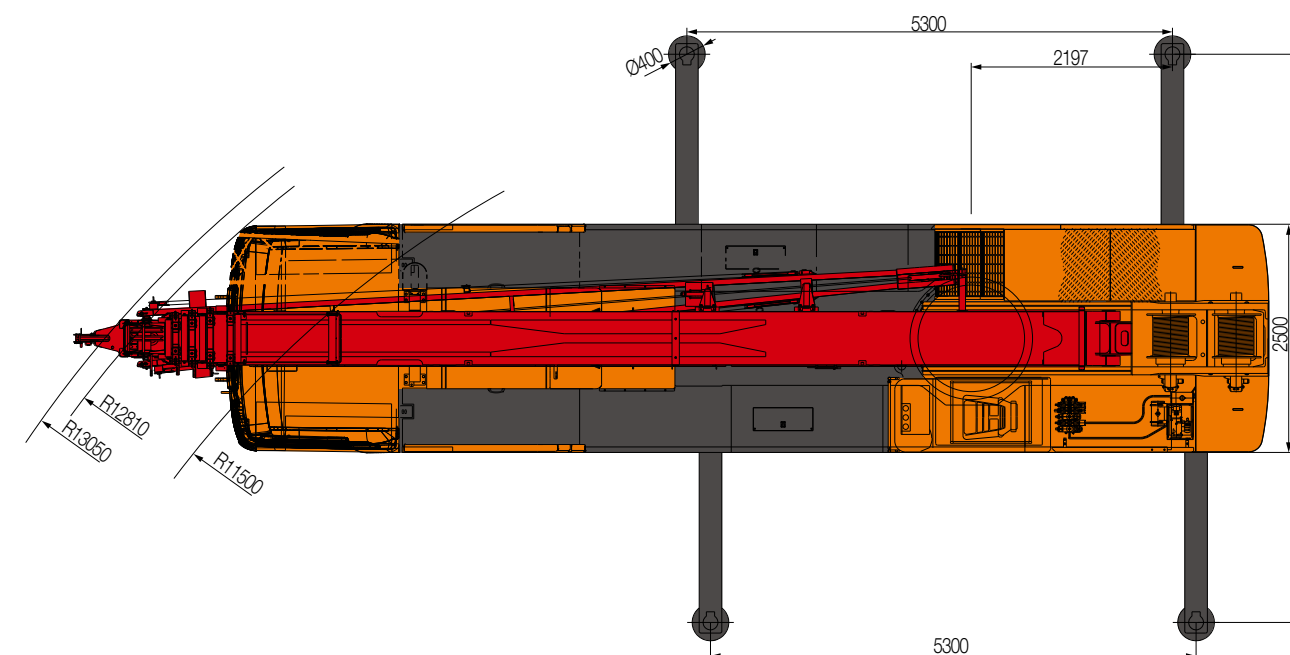
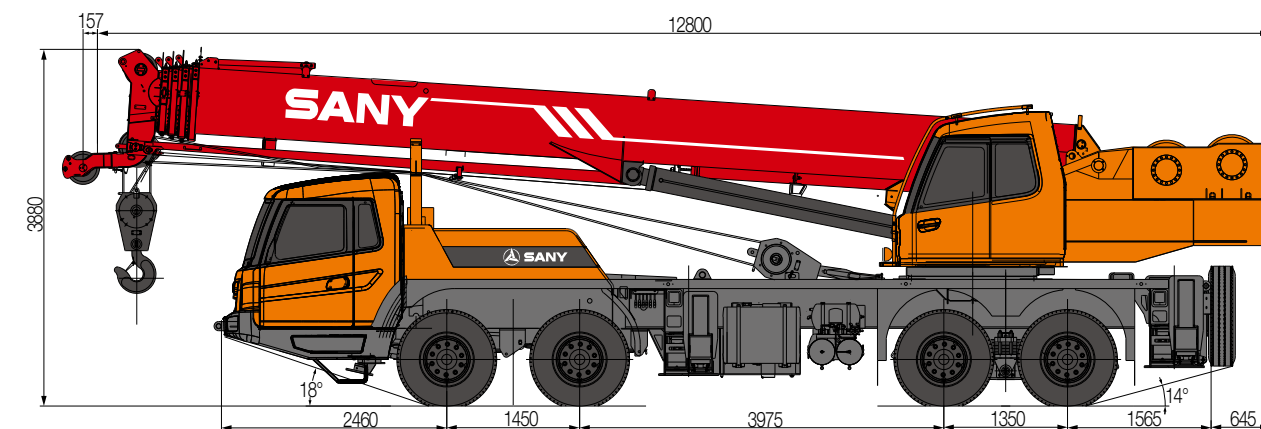

| Type | Item | Parameter |
|---|--|---|
| Capacity | Max. lifting capacity | 30t |
| Dimensions | Overall length | 12800mm |
| | Overall width | 2500mm |
| | Overall height | 3880mm |
| | Axle distance | Axle-1,2: 1450mm Axle-2,3: 3975mm Axle-3,4: 1350mm |
| Weight | Overall weight | 33600kg |
| | Axle load | Axle load-1,2: 11500kg Axle load-3,4: 22100kg |
| | Rated power | 213kW/2100rpm |
| | Rated torque | 1050N.m/1200~1400rpm |
| Traveling | Max.traveling speed | 80km/h |
| | Turning radius | Min.turning radius: 11.5m Min.turning radius of boom head: 13.5m |
| | Wheel formula | 8×4 |
| | Min.ground clearance | 220mm |
| | Approach angle | 19° |
| | Departure angle | 14.5° |
| | Max.gradeability | 35% |
| | Fuel consumption per 100km | ≤40L |
| | Main Performance Data | Temperature range |
| Min.rated range | | 3 m |
| Tail slewing radius of swingtable | | 3.37m |
| Boom section | | 5 |
| Boom shape | | U-shaped |
| Max.lifting moment | | Base boom: 1132kN·m Full-extend boom: 600kN·m Full-extend boom+jib: 380kN·m |
| Boom length | | Base boom: 10.5m Full-extend boom: 39.5m Full-extend boom+jib: 48m |
| Outrigger span (Longitudinal×Transversal) | | 5.3×6.2m |
| Jib offset | | 5°, 17°, 30° |
| Working speed | | Max.single rope lifting speed of main winch (no load) |
| | Max.single rope lifting speed of auxiliary winch (no load) | 118m/min |
| | Full extension/retraction time of boom | 105/110s |
| | Full lifting/descending time of boom | 50/60s |
| | Slewing speed | 2.2r/min |
| Aircondition | Aircondition in up cab | Heating/Cooling |
| | Aircondition in low cab | Heating/Cooling |

STC300H Working Ranges

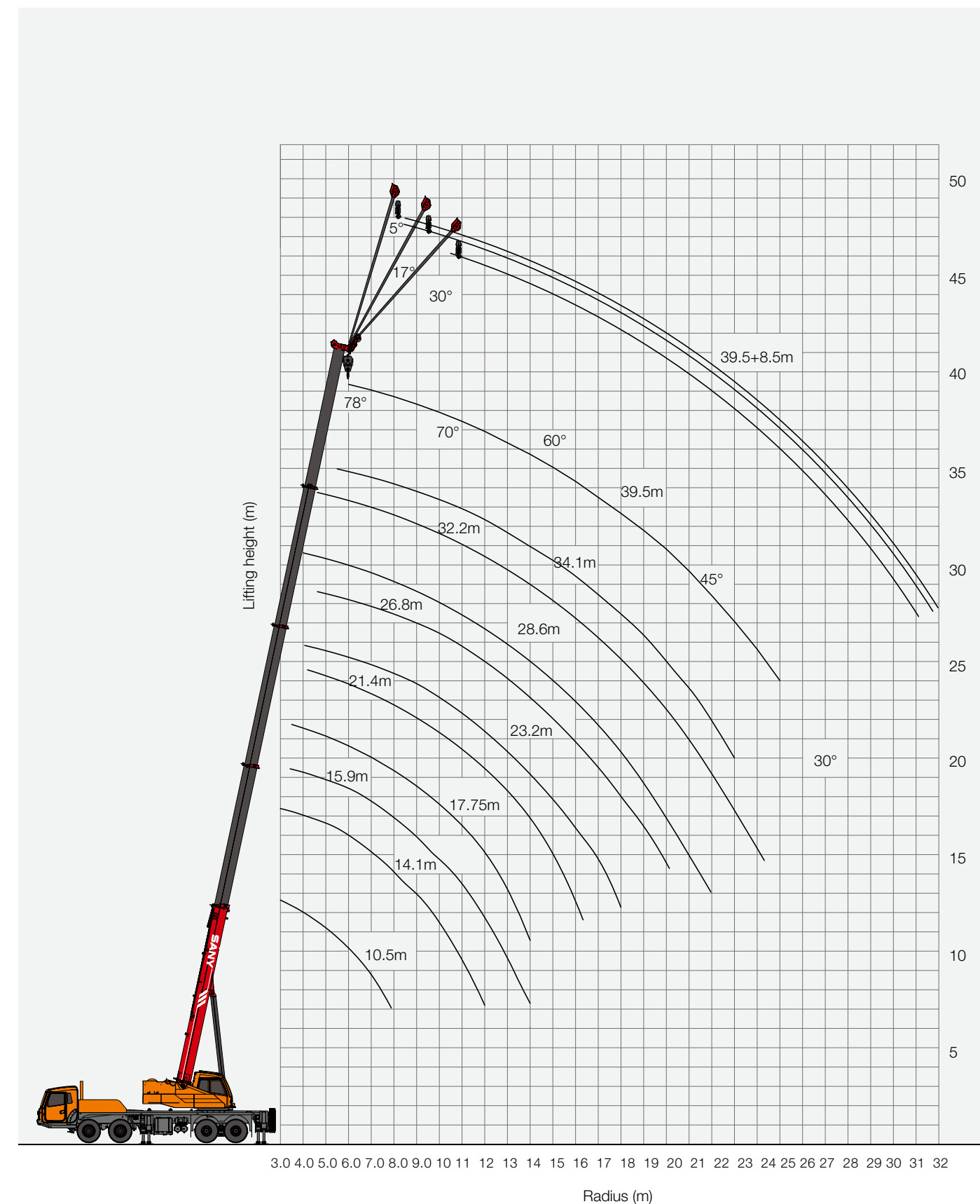

Unit:Kg

Full-extend outriggers, boom operation condition(full extend boom)the shortest 10.5m,the longest 39.5m, over side and rear, with max. span up to 5.3m×6.2m. 4.5t counterweight,360°rotation

| Working range(m) | Main boom | | | | | | | | | | | Working range(m) |
|----------------------|-----------|-------|-------|--------|-------|-------|-------|-------|-------|-------|-------|------------------|
| | 10.5m | 14.1m | 15.9m | 17.75m | 21.4m | 23.2m | 26.8m | 28.6m | 32.2m | 34.1m | 39.5m | |
| 3 | 30000 | 27000 | 12000 | | | | | | | | | 3 |
| 3.5 | 30000 | 27000 | 12000 | | | | | | | | | 3.5 |
| 4 | 27000 | 26000 | 11000 | 20000 | 10000 | 12000 | | | | | | 4 |
| 4.5 | 25000 | 24000 | 10000 | 18500 | 10000 | 12000 | | | | | | 4.5 |
| 5 | 23000 | 21800 | 9500 | 17000 | 8500 | 12000 | 7000 | 11500 | | | | 5 |
| 5.5 | 21000 | 20000 | 9000 | 15700 | 8200 | 12000 | 7000 | 11500 | | | | 5.5 |
| 6 | 18600 | 18000 | 8500 | 14700 | 7800 | 12000 | 6500 | 11000 | | | | 6 |
| 6.5 | 16500 | 16000 | 8000 | 13700 | 7500 | 11600 | 6100 | 10300 | 5000 | 8200 | | 6.5 |
| 7 | 14600 | 14000 | 7500 | 12800 | 7000 | 10800 | 5500 | 9700 | 5000 | 8200 | | 7 |
| 8 | 11600 | 11000 | 7000 | 11000 | 6300 | 9500 | 5100 | 8600 | 4800 | 7600 | 6000 | 8 |
| 9 | | 9000 | 6500 | 9100 | 5800 | 8500 | 4900 | 7700 | 4500 | 7100 | 6000 | 9 |
| 10 | | 7300 | 6000 | 7500 | 5400 | 7600 | 4700 | 7000 | 4100 | 6400 | 5600 | 10 |
| 11 | | 6200 | 5500 | 6400 | 4500 | 6700 | 4400 | 6400 | 3800 | 5850 | 5200 | 11 |
| 12 | | | 5000 | 5200 | 4400 | 5850 | 4000 | 5800 | 3500 | 5400 | 4800 | 12 |
| 13 | | | 4500 | 4400 | 4300 | 5050 | 3700 | 5200 | 3300 | 5000 | 4500 | 13 |
| 14 | | | | 3600 | 4000 | 4300 | 3500 | 4500 | 3100 | 4600 | 4200 | 14 |
| 15 | | | | | 3500 | 3700 | 3300 | 3900 | 2900 | 4200 | 4000 | 15 |
| 16 | | | | | 3100 | 3150 | 3100 | 3600 | 2700 | 3700 | 3700 | 16 |
| 18 | | | | | 2250 | 2300 | 2850 | 2700 | 2500 | 3000 | 3000 | 18 |
| 20 | | | | | | 1500 | 2450 | 2100 | 2200 | 2300 | 2400 | 20 |
| 22 | | | | | | | 1900 | 1600 | 1950 | 1800 | 1900 | 22 |
| 24 | | | | | | | | 1200 | 1650 | 1400 | 1500 | 24 |
| 26 | | | | | | | | | 1250 | 1000 | 1150 | 26 |
| 28 | | | | | | | | | 950 | 700 | 850 | 28 |
| 30 | | | | | | | | | | | 650 | 30 |
| 32 | | | | | | | | | | | 500 | 32 |
| Telescopic condition | | | | | | | | | | | | |
| Two-section | 0 | 50 | 0 | 100 | 0 | 100 | 0 | 100 | 0 | 100 | 100 | Two-section |
| Three-section | 0 | 0 | 25 | 0 | 50 | 25 | 75 | 50 | 100 | 75 | 100 | Three-section |
| Four-section | 0 | 0 | 25 | 0 | 50 | 25 | 75 | 50 | 100 | 75 | 100 | Four-section |
| Five-section | 0 | 0 | 25 | 0 | 50 | 25 | 75 | 50 | 100 | 75 | 100 | Five-section |
| Wire rope ratio | 8 | 8 | 6 | 6 | 4 | 4 | 4 | 4 | 4 | 4 | 3 | Wire rope ratio |

1. Values listed in the table refer to rated lifting capacity measured at flat and solid ground under the lever state of the crane;Value above heavy line shall be determined by strength of the crane and under this line shall be determined by stability of the crane;
2. The above parameters are based on full-extending state of outriggers, which must be complied with for lifting at side and rear.lifting with non-extended outrigger is forbidden
3. Value above heavy line shall be determined by strength of the crane and under this line shall be determined by stability of the crane;
4. Rated lifting capacity listed in the table included weights of lifting hooks (360kg of main hook and 100kg of auxiliary hook)and hangers;
5. Range value in the table is actual horizontal distance from center of lifted hook to center of rotation.
6. When actual boom length and working range are between those two values,larger values shall be applied to determine lifting capacity.
7. Lifting capacity of single pulley at the end of boom is same with that under 39.5m boom operating condition,with max.value 3.5t.
8. If jib is equipped at end of boom,lifting capacity of main hook is value that lifting capacity specified in table is reduced by 550kg for all operating conditions.



















Unit:Kg

Full-extend outriggers, with max. span up to 5.3m×6.2m. over side and rear,4.5t counterweight,360°rotation

| Main boom angle(°) | 39.5m+8.5m | | |
|--------------------|-----------------------|------------------------|------------------------|
| | Compensation angle 5° | Compensation angle 17° | Compensation angle 30° |
| 78° | 2700 | 2400 | 1800 |
| 75° | 2700 | 2300 | 1650 |
| 72° | 2500 | 2100 | 1600 |
| 70° | 2400 | 1900 | 1500 |
| 65° | 1900 | 1600 | 1250 |
| 60° | 1450 | 1350 | 1000 |
| 55° | 900 | 800 | 700 |
| 50° | 600 | 500 | 400 |

STC300H TRUCK CRANE
WHEEL CRANE FAMILY MAP

■ TRUCK CRANE

| | | | | |
|--|--|--|---|---|
|  STC200 Maximum Load Capacity: 20t Telescopic Boom: 4 Sections, 10.6-33m |  STC250 Maximum Load Capacity: 25t Telescopic Boom: 4 Sections, 10.6-33.5m |  STC250H Maximum Load Capacity: 25t Telescopic Boom: 5 Sections, 10.5-39.5m |  STC300S Maximum Load Capacity: 30t Telescopic Boom: 5 Sections, 10.6-40.5m |  STC300TH Maximum Load Capacity: 30t Telescopic Boom: 4 Sections, 10.6-33.5m |
|  STC300H Maximum Load Capacity: 30t Telescopic Boom: 5 Sections, 10.5-39.2m |  STC500 Maximum Load Capacity: 50t Telescopic Boom: 5 Sections, 11.5-43m |  STC550 Maximum Load Capacity: 55t Telescopic Boom: 5 Sections, 11.5-43m |  STC600S Maximum Load Capacity: 60t Telescopic Boom: 5 Sections, 11.3-43.5m |  STC750 Maximum Load Capacity: 75t Telescopic Boom: 5 Sections, 11.8-45m |
|  STC800S Maximum Load Capacity: 80t Telescopic Boom: 5 Sections, 12.2-47m |  STC1000 Maximum Load Capacity: 100t Telescopic Boom: 5 Sections, 13.5-52m |  STC1000C Maximum Load Capacity: 100t Telescopic Boom: 6 Sections, 13.25-60m |  STC1000S Maximum Load Capacity: 100t Telescopic Boom: 5 Sections, 12.28-56m |  STC1200S Maximum Load Capacity: 120t Telescopic Boom: 7 Sections, 12.6-63.5m |
|  STC1300C Maximum Load Capacity: 130t Telescopic Boom: 6 Sections, 13.3-60m |  STC1600 Maximum Load Capacity: 160t Telescopic Boom: 6 Sections, 13.4-62m |  STC2200 Maximum Load Capacity: 220t Telescopic Boom: 6 Sections, 14.55-68m | | |

■ ALL TERRAIN CRANE

| | | | |
|---|--|---|---|
|  SAC1800 Maximum Load Capacity: 180t Telescopic Boom: 6 Sections, 13.5-62m |  SAC2200 Maximum Load Capacity: 220t Telescopic Boom: 6 Sections, 13.5-62m |  SAC2600 Maximum Load Capacity: 260t Telescopic Boom: 6 Sections, 15.65-73m |  SAC3000 Maximum Load Capacity: 300t Telescopic Boom: 7 Sections, 15.8-83m |
|  SAC3500 Maximum Load Capacity: 350t Telescopic Boom: 6 Sections, 15.2-70m |  SAC6000 Maximum Load Capacity: 600t Telescopic Boom: 7 Sections, 17.1-90m | | |

■ ROUGH-TERRAIN CRANE

| | | | | |
|--|--|---|--|--|
|  SRC250 Maximum Load Capacity: 25t Telescopic Boom: 4 Sections, 9.9-31.5m |  SRC350 Maximum Load Capacity: 35t Telescopic Boom: 4 Sections, 10-31.5m |  SRC550 Maximum Load Capacity: 55t Telescopic Boom: 4 Sections, 11.25-34.5m |  SRC550H Maximum Load Capacity: 55t Telescopic Boom: 5 Sections, 11.5-43m |  SRC750 Maximum Load Capacity: 75t Telescopic Boom: 5 Sections, 11.8-45m |
|  SRC1200 Maximum Load Capacity: 120t Telescopic Boom: 5 Sections, 13-49m | | | | |



Quality Changes the World

SANY AUTOMOBILE HOISTING MACHINERY

Address: SANY Industrial Park, Jinzhou Development Zone,
Changsha, Hunan, China.
Service Hotline: 4006098318
Email: crd@sany.com.cn
For more information, please visit: www.sanygroup.com

For our consistent improvement in technology, specifications may change without notice.
The machines illustrated may show optional equipment which can be supplied at additional cost.

Version: 2015.08

Distributed By:

| |
|--|
| |
|--|