



SANY PAVERS



SANY HEAVY INDUSTRY CO., LTD.

SANY Industry Town, Changsha Economic and Technological
Development Zone, Hunan Province, China
Service Line: +86 4006 098 318
E-mail: crd@sany.com.cn

www.sanygroup.com

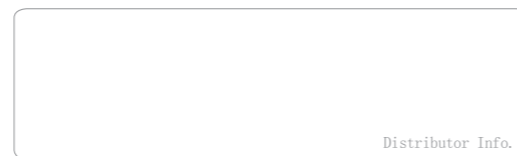

Distributor Info.

Due to our process of continuous innovation, materials and specifications are subject to change without notice.

© Printed in China File No.: 59010962 Date: Mar 2016

Contents

THE LEADING BRAND IN CHINA WITH WORLD CLASS QUALITY

Sany won the "Number One Brand of Paver in China" award in 2011.
Sany paver sales have been ranked number one in China for the last 5 consecutive years.



- P03 SSP SERIES STABILIZED SOIL PAVER
- P07 SAP SERIES ASPHALT PAVER
- P11 LEAN MANUFACTURING
- P13 TEST SYSTEM



SANY SSP STABILIZED SOIL PAVER

No.1 brand in China, specially designed for heavy thickness stabilized layer pavement.

POWERFUL POWER PLANT

- ◆ 180 kW engine satisfies demanding power requirements.

EFFICIENCY

- ◆ Paving capability of over 900 tons per hour.
- ◆ Capable of paving a mat up to 50 cm thick! The highest in the industry.
- ◆ 2 persons can assemble the 9.5m bolt-on screed in 2 hours.

ECONOMICAL

- ◆ Conveyor is made of thickened, wear resistant steel plate with a service life in excess of 2000 hours.
- ◆ Designed to endure non-stop paving operations in 50 degree Celsius temperatures.



TECHNICAL SPECIFICATIONS

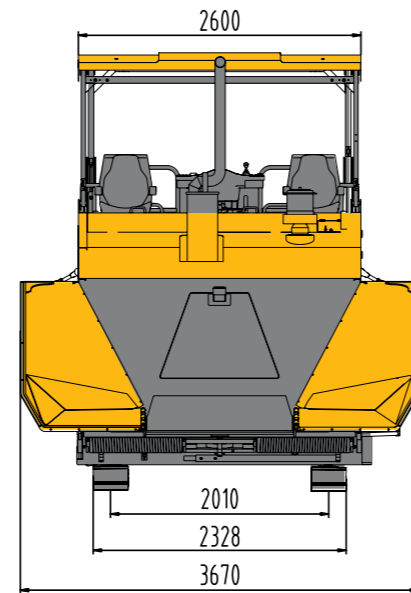
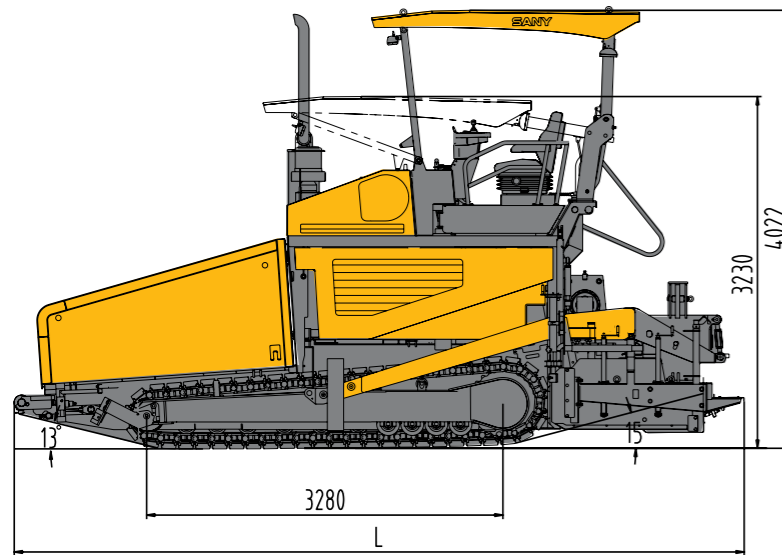

SSP Series Stabilized Soil Paver Technical Parameters

Model	SSP220C-6S	
Paving Capacity (t/h)	900	
Paving Width (m)	Bolted:10	
	Hydraulic:9	
	Hydraulic:8	
Basic Width (m)	Bolted:2.5	
	Hydraulic: 3~5.7	
	Hydraulic: 2.5~4.7	
Max. Paving Thickness (cm)	50	
Working Speed (m/min)	0.8 ~ 16	
Travel Speed (km/h)	0 ~ 3	
Transport Dimensions (mm)	Bolted:6717×2710×3230	
	Hydraulic:7200×3000×3230	
	Hydraulic:7200×2710×3230	
Engine Model	Sany	
	D07S3T2	
Rated Power of Engine (kW)	180	
Rated Speed of Engine (RPM)	2000	
Emissions	Tier III	
Voltage of Electric System (V)	24	
Gradeability	≥20%	
Hopper Capacity (m ³)	8.5	
Vibration Frequency (Hz)	0 ~ 50	
Heating Mode	Bolted: Gas Heated	
	Hydraulic: Electric Heated	
Camber Adjustment Range (%)	-1 ~ 3	
Quantity of Tamper	Bolted:2	
	Hydraulic:1	
Tamping Amplitude (mm)	Bolted:	Main : 3/5/8/10
		Auxiliary : 5
	Hydraulic:0/2/4/6/8	
Tamping Frequency (Hz)	0 ~ 25	

SANY SAP SERIES ASPHALT PAVER

EXCELLENT PAVING PERFORMANCE

- ◆ High strength screed—the strongest, most rigid design in the industry. Uses a frame structure with double layer anti-twist beams to produce consistently stable work.
- ◆ Anti-segregation technology used in all aspects of material handling. Fully proportional, independent conveyor and auger controls match device speeds to paving speed - fully and independently adjustable for various material types.
- ◆ To provide the ultimate in product support, machine controllers can be remotely monitored and even updated!

STABLE AND RELIABLE

- ◆ Wiring harnesses built to industry standards to provide solid connections and protection against heat, cold and moisture.
- ◆ The machine and its systems are designed to work non-stop, 24 hours a day under full load in a 50 degree Celsius environment.



TECHNICAL SPECIFICATIONS

Size Code	SAP130C-6	SAP200C-6S	SAP240C-6S
A(mm)	3750	3890	3890
B(mm)	3050	3230	3230
C(mm)	2570	3278	3278
D (°)	12	13	13
E (°)	15	15	15
F(mm)	2100	2600	2600
G(mm)	1505	2022	2022
H(mm)	3265	3470	3470
L(mm)	6500	6780(SF250)	6780(SF250)
		7080(SE570/SE470)	7080(SE570/SE470)

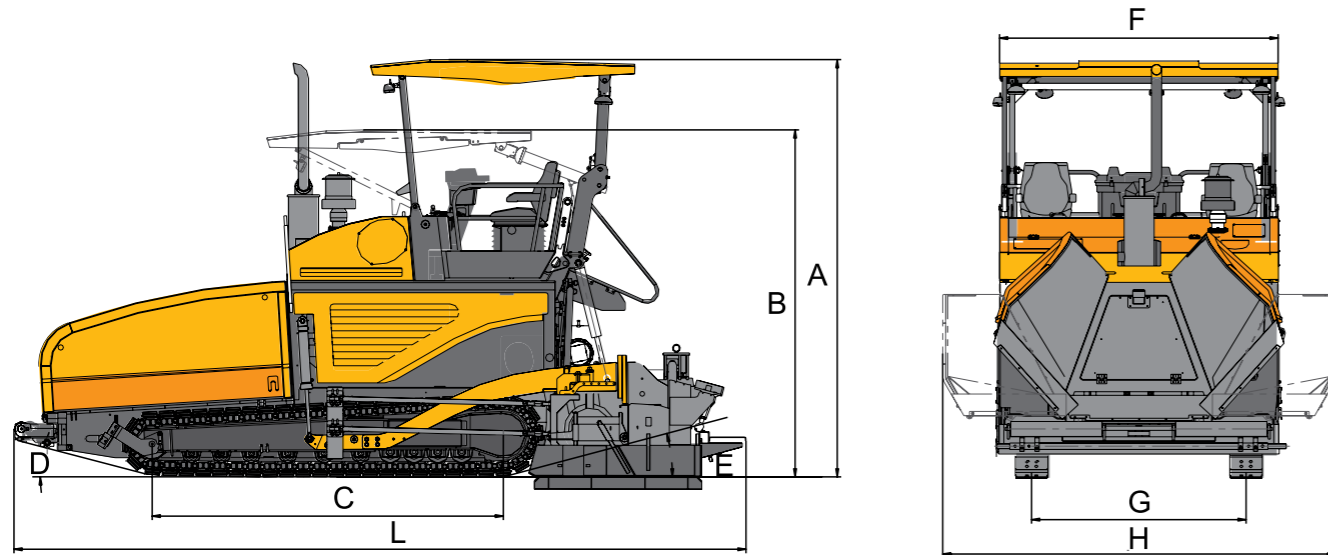

SAP Series Asphalt Paver Technical Parameters

Model	SAP130C-6	SAP200C-6S	SAP240C-6S
Paving Capacity (t/h)	450	900	1100
Paving Width (m)	6	Bolted: 10	Bolted:12
		Hydraulic: 9	Hydraulic:9
		Hydraulic:8	Hydraulic:8
Basic Width (m)	2~3.7	Bolted:2.5	Bolted:2.5
		Hydraulic: 3~5.7	Hydraulic: 3~5.7
		Hydraulic: 2.5~4.7	Hydraulic: 2.5~4.7
Max. Paving Thickness (cm)	25	35	35
Working Speed (m/min)	1 ~ 20	0.8 ~ 16	0.8 ~ 24
Travel Speed (km/h)	0 ~ 2.5	0 ~ 3	0 ~ 4.5
Transport Dimensions (mm)	6320×2100×3060	Bolted:6780×2710×3230	Bolted:6780×2710×3230
		Hydraulic: 7080×3210×3230	Hydraulic: 7080×3210×3230
		Hydraulic: 7080×2710×3230	Hydraulic: 7080×2710×3230
Engine Model	Cummins	Sany	Sany
	QSB4.5-C130	D07S3T2	D07S3T2
Rated Power of Engine (kW)	97	180	180
Rated Speed of Engine (RPM)	2000	2000	2000
Emissions	Tier III	Tier III	Tier III
Voltage of Electric System (V)	24	24	24
Gradeability	≥20%	≥20%	≥20%
Hopper Capacity (m ³)	6	8.5	8.5
Vibration Frequency (Hz)	0 ~ 40	0 ~ 50	0 ~ 50
Heating Mode	Electric Heated	Electric Heated	Electric Heated
Camber Adjustment Range (%)	-1 ~ 3	-1 ~ 3	-1 ~ 3
Quantity of Tamper	1	1	1
Tamping Amplitude (mm)	4	Bolted:3/5/8/10	Bolted:3/5/8/10
		Hydraulic:0/2/4/6/8	Hydraulic:0/2/4/6/8
Tamping Frequency (Hz)	0 ~ 25	0 ~ 25	Bolted:0~30
			Hydraulic:0~25

LEAN MANUFACTURING

Sany employees constantly strive for perfection and to constantly set the standards for Chinese manufacturing. These efforts are behind all of our "Number One" achievements in product performance and manufacturing excellence.



Imported Machining Production Line



Flexible line of imported horizontal machining center



Professional Inventory Management and Damage-Prevention Measures



● World's Biggest Vehicle Assembly Line

SANY 减少浪费 提升品质 整齐舒适 安全规范
SANY 依托中国梦 实现三一梦



Sany's Digitalized Asphalt Batching Plant Base in Changde City



Dust-free Constant Temperature Precision Transmission Workshop

The company has achieved complete flow-line manufacturing of road machinery through elaborate design, optimized layout and controlled quality. Our continuous technical innovation process evaluates new technologies, new materials such as information oriented production management, fully automated robotic welding, AGV's and automated high-rise warehouses. The company implements rigorous quality control to ensure that each product is free of defects and performs flawlessly from the day it is delivered, well into complex, adverse working conditions.

TEST SYSTEM



Gradeability and Approach Angle



Compactness Meter



Infrared Thermal Imager



Profilometer



Screed Test



Depth Measurement of Surface Texture

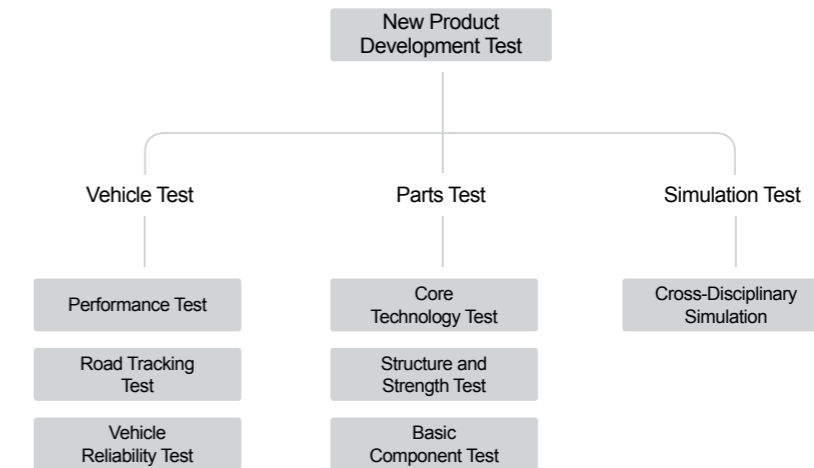

R&D and Test System

To build the leading road machinery R&D platform in the world, Sany Road Machinery has at its disposal 9 testing and checking centers and 58 labs to form a cross-disciplinary and cross-sector product development work flow. The 9 testing and checking centers include: the Construction Machinery Remote Monitoring Service and Fault-Diagnosis Lab, the Hydraulics Lab, the Mechanical-Electrical-Hydraulic and Simulation Lab, the Diesel Engine Lab, the Equipment Fatigue (Working Life) Lab, the Welding Lab, the Strength (Stress) Test Lab, the Wear Resistant Material Test Lab, and the Chassis Auto Check Lab. Through working on the testing process, new product development test, customer experience platform, and the work conditions simulation data base, we have put in place a three stage testing system comprising vehicle test, parts and components test, and simulation test. Our system has the capacity to develop asphalt batching plants, asphalt pavers, motor graders, rollers, and cold planers. The research and testing capacity of our core technologies has significantly enhanced our research abilities.

